

# Physics 2204

*Curriculum Guide 2018*



Education and Early Childhood Development



***Department of Education and Early  
Childhood Development  
Mission Statement***

***The Department of Education and Early Childhood Development  
will improve provincial early childhood learning and the K-12  
education system to further opportunities for the people of  
Newfoundland and Labrador.***

---

---

# Acknowledgments

The Department of Education and Early Childhood Development gratefully acknowledges the contribution of the following individuals in the development and completion of the *Physics 2204 Curriculum Guide (2018)*:

Amanda Craig  
Gonzaga High School

Brent Davis  
CDLI

Carl Winter  
Clarenville High School

Daryl Pinksen  
Prince of Wales Collegiate

David Warren  
CDLI

Denika Saunders  
Indian River High School

Doug Crews  
Queen Elizabeth Regional High School

Jennifer Bennett  
Gander Collegiate

John French  
Corner Brook Regional High School

Nicole Ash  
St. Kevin's High School

Paul King  
Mt. Pearl Senior High School

Renee Boyce  
Holy Spirit High School

Robert Brake  
Holy Heart High School

Sheldon Critch  
Botwood Collegiate

Steven Murphy  
Menihek High School

Thomas N. Pike  
St. James Regional High



---

# Table of Contents

Acknowledgements .....	v
<b>Section One: Newfoundland and Labrador Curriculum</b>	
Outcomes Based Education.....	1
Context for Teaching and Learning .....	4
Inclusive Education.....	4
Literacy .....	10
Learning Skills for Generation Next.....	12
Assessment and Evaluation.....	15
<b>Section Two: Curriculum Design</b>	
Rationale .....	19
Curriculum Outcomes Framework .....	20
Course Overview.....	23
Suggested Yearly Plan .....	23
How to use a Four Column Layout.....	24
How to use a Strand Overview.....	26
<b>Section Three: Specific Curriculum Outcomes</b>	
Unit i: Integrated Skills .....	27
Unit 1: Kinematics .....	63
Unit 2: Dynamics .....	79
Unit 3: Work and Energy .....	
Unit 4: Waves.....	
Appendices.....	





---

# Section One: Newfoundland and Labrador Curriculum

## Introduction

There are multiple factors that impact education: technological developments, increased emphasis on accountability, and globalization. These factors point to the need to consider carefully the education students receive.

The Newfoundland and Labrador Department of Education and Early Childhood Development believes that curriculum design with the following characteristics will help teachers address the needs of students served by the provincially prescribed curriculum:

- Curriculum guides must clearly articulate what students are expected to know and be able to do by the time they graduate from high school.
- There must be purposeful assessment of students' performance in relation to the curriculum outcomes.

## Outcomes Based Education

The K-12 curriculum in Newfoundland and Labrador is organized by outcomes and is based on *The Atlantic Canada Framework for Essential Graduation Learning in Schools* (1997). This framework consists of Essential Graduation Learnings (EGLs), General Curriculum Outcomes (GCOs), Key Stage Curriculum Outcomes (KSCOs) and Specific Curriculum Outcomes (SCOs).

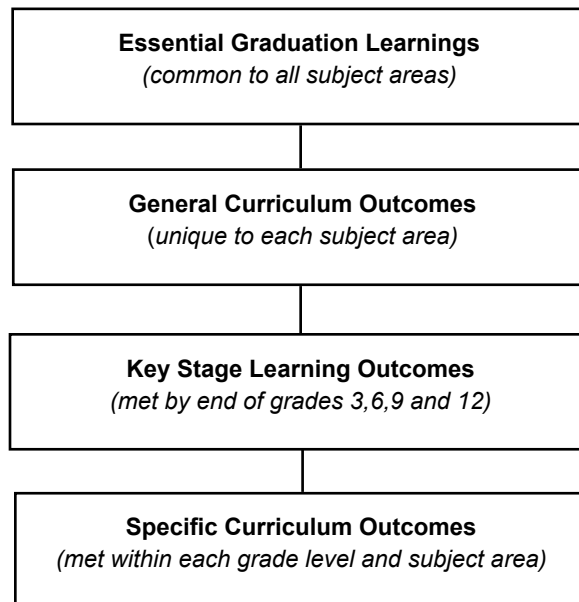

### *Essential Graduation Learnings*

EGLs provide vision for the development of a coherent and relevant curriculum. They are statements that offer students clear goals and a powerful rationale for education. The EGLs are delineated by general, key stage, and specific curriculum outcomes.

EGLs describe the knowledge, skills, and attitudes expected of all students who graduate from high school. Achievement of the EGLs will prepare students to continue to learn throughout their lives. EGLs describe expectations, not in terms of individual subject areas, but in terms of knowledge, skills, and attitudes developed throughout the K-12 curriculum. They confirm that students need to make connections and develop abilities across subject areas if they are to be ready to meet the shifting and ongoing demands of life, work, and study.

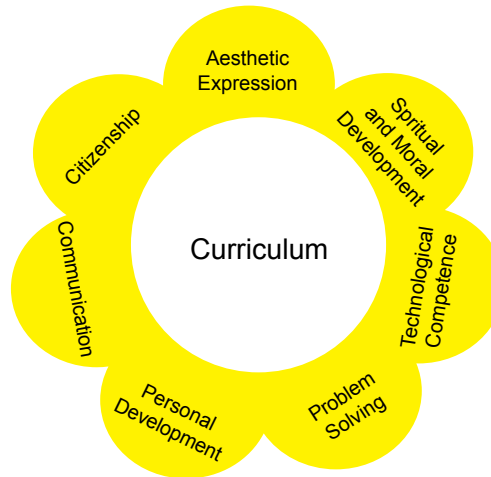

**Aesthetic Expression** – Graduates will be able to respond with critical awareness to various forms of the arts and be able to express themselves through the arts.

**Citizenship** – Graduates will be able to assess social, cultural, economic, and environmental interdependence in a local and global context.

**Communication** – Graduates will be able to use the listening, viewing, speaking, reading and writing modes of language(s), and mathematical and scientific concepts and symbols, to think, learn and communicate effectively.

**Problem Solving** – Graduates will be able to use the strategies and processes needed to solve a wide variety of problems, including those requiring language, and mathematical and scientific concepts.

**Personal Development** – Graduates will be able to continue to learn and to pursue an active, healthy lifestyle.

**Spiritual and Moral Development** – Graduates will demonstrate understanding and appreciation for the place of belief systems in shaping the development of moral values and ethical conduct.

**Technological Competence** – Graduates will be able to use a variety of technologies, demonstrate an understanding of technological applications, and apply appropriate technologies for solving problems.

## Curriculum Outcomes

Curriculum outcomes are statements that articulate what students are expected to know and be able to do in each program area in terms of knowledge, skills, and attitudes.

Curriculum outcomes may be subdivided into General Curriculum Outcomes, Key Stage Curriculum Outcomes, and Specific Curriculum Outcomes.

### **General Curriculum Outcomes (GCOs)**

Each program has a set of GCOs which describe what knowledge, skills, and attitudes students are expected to demonstrate as a result of their cumulative learning experiences within a subject area. GCOs serve as conceptual organizers or frameworks which guide study within a program area. Often, GCOs are further delineated into KSCOs.

### **Key Stage Curriculum Outcomes (KSCOs)**

Key Stage Curriculum Outcomes (KSCOs) summarize what is expected of students at each of the four key stages of grades three, six, nine, and twelve.

### **Specific Curriculum Outcomes (SCOs)**

SCOs set out what students are expected to know and be able to do as a result of their learning experiences in a course, at a specific grade level. In some program areas, SCOs are further articulated into delineations. *It is expected that all SCOs will be addressed during the course of study covered by the curriculum guide.*

## EGLs to Curriculum Guides

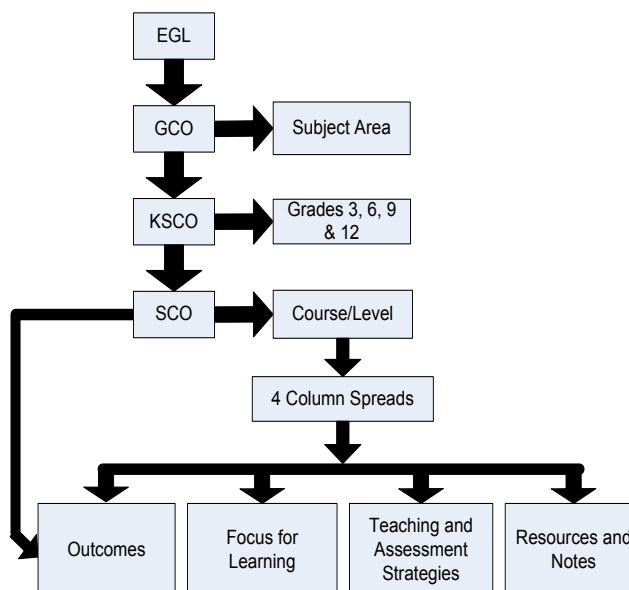

## Context for Teaching and Learning

Teachers are responsible to help students achieve outcomes. This responsibility is a constant in a changing world. As programs change over time so does educational context. Several factors make up the educational context in Newfoundland and Labrador today: inclusive education, support for gradual release of responsibility teaching model, focus on literacy and learning skills in all programs, and support for education for sustainable development.

### Inclusive Education

#### *Valuing Equity and Diversity*

*Effective inclusive schools have the following characteristics: supportive environment, positive relationships, feelings of competence, and opportunities to participate. (The Centre for Inclusive Education, 2009)*

All students need to see their lives and experiences reflected in their school community. It is important that the curriculum reflect the experiences and values of all genders and that learning resources include and reflect the interests, achievements, and perspectives of all students. An inclusive classroom values the varied experiences and abilities as well as social and ethno-cultural backgrounds of all students while creating opportunities for community building. Inclusive policies and practices promote mutual respect, positive interdependencies, and diverse perspectives. Learning resources should include a range of materials that allow students to consider many viewpoints and to celebrate the diverse aspects of the school community.



## Differentiated Instruction

*Differentiated instruction is a teaching philosophy based on the premise that teachers should adapt instruction to student differences. Rather than marching students through the curriculum lockstep, teachers should modify their instruction to meet students' varying readiness levels, learning preferences, and interests. Therefore, the teacher proactively plans a variety of ways to 'get it' and express learning. (Carol Ann Tomlinson, 2008)*

Curriculum is designed and implemented to provide learning opportunities for all students according to abilities, needs, and interests. Teachers must be aware of and responsive to the diverse range of learners in their classes. Differentiated instruction is a useful tool in addressing this diversity.

Differentiated instruction responds to different readiness levels, abilities, and learning profiles of students. It involves actively planning so that the process by which content is delivered, the way the resource is used, and the products students create are in response to the teacher's knowledge of whom he or she is interacting with. Learning environments should be flexible to accommodate various learning preferences of the students. Teachers continually make decisions about selecting teaching strategies and structuring learning activities that provide all students with a safe and supportive place to learn and succeed.

### Planning for Differentiation

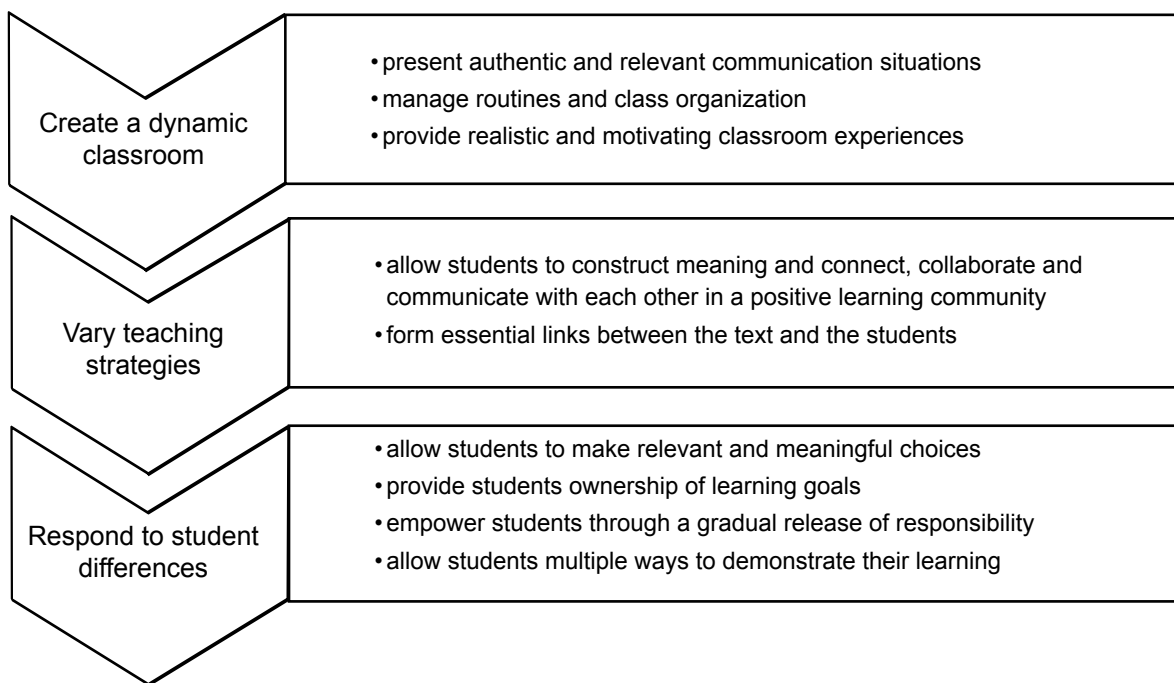

## Differentiating the Content

Differentiating content requires teachers to pre-assess students to identify those who require prerequisite instruction, as well as those who have already mastered the concept and may therefore apply strategies learned to new situations. Another way to differentiate content is to permit students to adjust the pace at which they progress through the material. Some students may require additional time while others will move through at an increased pace and thus create opportunities for enrichment or more in-depth consideration of a topic of particular interest.

Teachers should consider the following examples of differentiating content:

- Meet with small groups to reteach an idea or skill or to extend the thinking or skills.
- Present ideas through auditory, visual, and tactile means.
- Use reading materials such as novels, websites, and other reference materials at varying reading levels.

### *Differentiating the Process*

Differentiating the process involves varying learning activities or strategies to provide appropriate methods for students to explore and make sense of concepts. A teacher might assign all students the same product (e.g., presenting to peers) but the process students use to create the presentation may differ. Some students could work in groups while others meet with the teacher individually. The same assessment criteria can be used for all students.

Teachers should consider flexible grouping of students such as whole class, small group, or individual instruction. Students can be grouped according to their learning styles, readiness levels, interest areas, and/or the requirements of the content or activity presented. Groups should be formed for specific purposes and be flexible in composition and short-term in duration.

Teachers should consider the following examples of differentiating the process:

- Offer hands-on activities for students.
- Provide activities and resources that encourage students to further explore a topic of particular interest.
- Use activities in which all learners work with the same learning outcomes but proceed with different levels of support, challenge, or complexity.

### *Differentiating the Product*

Differentiating the product involves varying the complexity and type of product that students create to demonstrate learning outcomes. Teachers provide a variety of opportunities for students to demonstrate and show evidence of what they have learned.

Teachers should give students options to demonstrate their learning (e.g., create an online presentation, write a letter, or develop a mural). This will lead to an increase in student engagement.

## *Differentiating the Learning Environment*

The learning environment includes the physical and the affective tone or atmosphere in which teaching and learning take place, and can include the noise level in the room, whether student activities are static or mobile, or how the room is furnished and arranged. Classrooms may include tables of different shapes and sizes, space for quiet individual work, and areas for collaboration.

Teachers can divide the classroom into sections, create learning centres, or have students work both independently and in groups. The structure should allow students to move from whole group, to small group, pairs, and individual learning experiences and support a variety of ways to engage in learning. Teachers should be sensitive and alert to ways in which the classroom environment supports their ability to interact with students.

Teachers should consider the following examples of differentiating the learning environment:

- Develop routines that allow students to seek help when teachers are with other students and cannot provide immediate attention.
- Ensure there are places in the room for students to work quietly and without distraction, as well as places that invite student collaboration.
- Establish clear guidelines for independent work that match individual needs.
- Provide materials that reflect diversity of student background, interests, and abilities.

The physical learning environment must be structured in such a way that all students can gain access to information and develop confidence and competence.

## *Meeting the Needs of Students with Exceptionalities*

All students have individual learning needs. Some students, however, have exceptionalities (defined by the Department of Education and Early Childhood Development) which impact their learning. The majority of students with exceptionalities access the prescribed curriculum. For details of these exceptionalities see [www.gov.nl.ca/edu/k12/studentssupportservices/exceptionalities.html](http://www.gov.nl.ca/edu/k12/studentssupportservices/exceptionalities.html)

Supports for these students may include

1. Accommodations
2. Modified Prescribed Courses
3. Alternate Courses
4. Alternate Programs
5. Alternate Curriculum

For further information, see Service Delivery Model for Students with Exceptionalities at [www.cdli.ca/sdm/](http://www.cdli.ca/sdm/)

Classroom teachers should collaborate with instructional resource teachers to select and develop strategies which target specific learning needs.

*Meeting the Needs  
of Students who are  
Highly Able  
(includes gifted and  
talented)*

Some students begin a course or topic with a vast amount of prior experience and knowledge. They may know a large portion of the material before it is presented to the class or be capable of processing it at a rate much faster than their classmates. All students are expected to move forward from their starting point. Many elements of differentiated instruction are useful in addressing the needs of students who are highly able.

Teachers may

- assign independent study to increase depth of exploration in an area of particular interest;
- compact curriculum to allow for an increased rate of content coverage commensurate with a student's ability or degree of prior knowledge;
- group students with similar abilities to provide the opportunity for students to work with their intellectual peers and elevate discussion and thinking, or delve deeper into a particular topic; and
- tier instruction to pursue a topic to a greater depth or to make connections between various spheres of knowledge.

Highly able students require the opportunity for authentic investigation to become familiar with the tools and practices of the field of study. Authentic audiences and tasks are vital for these learners. Some highly able learners may be identified as gifted and talented in a particular domain. These students may also require supports through the Service Delivery Model for Students with Exceptionalities.



## *Gradual Release of Responsibility*

Teachers must determine when students can work independently and when they require assistance. In an effective learning environment, teachers choose their instructional activities to model and scaffold composition, comprehension, and metacognition that is just beyond the students' independence level. In the gradual release of responsibility approach, students move from a high level of teacher support to independent work. If necessary, the teacher increases the level of support when students need assistance. The goal is to empower students with their own learning strategies, and to know how, when, and why to apply them to support their individual growth. Guided practice supports student independence. As a student demonstrates success, the teacher should gradually decrease his or her support.

### *Gradual Release of Responsibility Model*

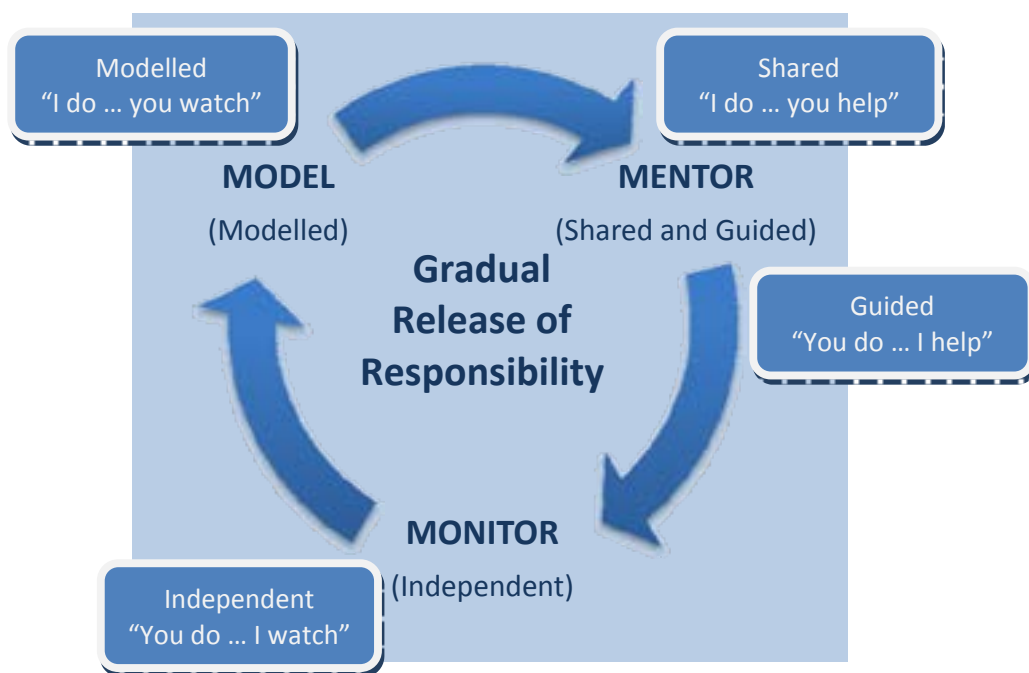

## Literacy

*“Literacy is the ability to identify, understand, interpret, create, communicate and compute, using printed and written materials associated with varying contexts. Literacy involves a continuum of learning in enabling individuals to achieve their goals, to develop their knowledge and potential, and to participate fully in their community and wider society”. To be successful, students require a set of interrelated skills, strategies and knowledge in multiple literacies that facilitate their ability to participate fully in a variety of roles and contexts in their lives, in order to explore and interpret the world and communicate meaning. (The Plurality of Literacy and its Implications for Policies and Programmes, 2004, p.13)*

Literacy is

- a process of receiving information and making meaning from it; and
- the ability to identify, understand, interpret, communicate, compute, and create text, images, and sounds.

Literacy development is a lifelong learning enterprise beginning at birth that involves many complex concepts and understandings. It is not limited to the ability to read and write; no longer are we exposed only to printed text. It includes the capacity to learn to communicate, read, write, think, explore, and solve problems. Individuals use literacy skills in paper, digital, and live interactions to engage in a variety of activities:

- Analyze critically and solve problems.
- Comprehend and communicate meaning.
- Create a variety of texts.
- Make connections both personally and inter-textually.
- Participate in the socio-cultural world of the community.
- Read and view for enjoyment.
- Respond personally.

These expectations are identified in curriculum documents for specific subject areas as well as in supporting documents, such as *Cross-Curricular Reading Tools (CAMET)*.

With modelling, support, and practice, students' thinking and understandings are deepened as they work with engaging content and participate in focused conversations.

## Reading in the Content Areas

The focus for reading in the content areas is on teaching strategies for understanding content. Teaching strategies for reading comprehension benefits all students as they develop transferable skills that apply across curriculum areas.

When interacting with different texts, students must read words, view and interpret text features, and navigate through information presented in a variety of ways including, but not limited to

Advertisements	Movies	Poems
Blogs	Music videos	Songs
Books	Online databases	Speeches
Documentaries	Plays	Video games
Magazine articles	Podcasts	Websites

Students should be able to interact with and comprehend different texts at different levels.

There are three levels of text comprehension:

- Independent level – Students are able to read, view, and understand texts without assistance.
- Instructional level – Students are able to read, view, and understand most texts but need assistance to fully comprehend some texts.
- Frustration level – Students are not able to read or view with understanding (i.e., texts may be beyond their current reading level).

Teachers will encounter students working at all reading levels in their classrooms and will need to differentiate instruction to meet their needs. For example, print texts may be presented in audio form, physical movement may be associated with synthesizing new information with prior knowledge, or graphic organizers may be created to present large amounts of print text in a visual manner.

When interacting with information that is unfamiliar to students, it is important for teachers to monitor how effectively students are using strategies to read and view texts:

- Analyze and think critically about information.
- Determine importance to prioritize information.
- Engage in questioning before, during, and after an activity related to a task, text, or problem.
- Make inferences about what is meant but not said.
- Make predictions.
- Synthesize information to create new meaning.
- Visualize ideas and concepts.

## Learning Skills for Generation Next

*Generation Next is the group of students who have not known a world without personal computers, cell phones, and the Internet. They were born into this technology. They are digital natives.*

Students need content and skills to be successful. Education helps students learn content and develop skills needed to be successful in school and in all learning contexts and situations. Effective learning environments and curricula challenge learners to develop and apply key skills within the content areas and across interdisciplinary themes.

Learning Skills for Generation Next encompasses three broad areas:

- Learning and Innovation Skills enhance a person's ability to learn, create new ideas, problem solve, and collaborate.
- Life and Career Skills address leadership, and interpersonal and affective domains.
- Literacy Skills develop reading, writing, and numeracy, and enhance the use of information and communication technology.

The diagram below illustrates the relationship between these areas. A 21<sup>st</sup> century curriculum employs methods that integrate innovative and research-driven teaching strategies, modern learning technologies, and relevant resources and contexts.

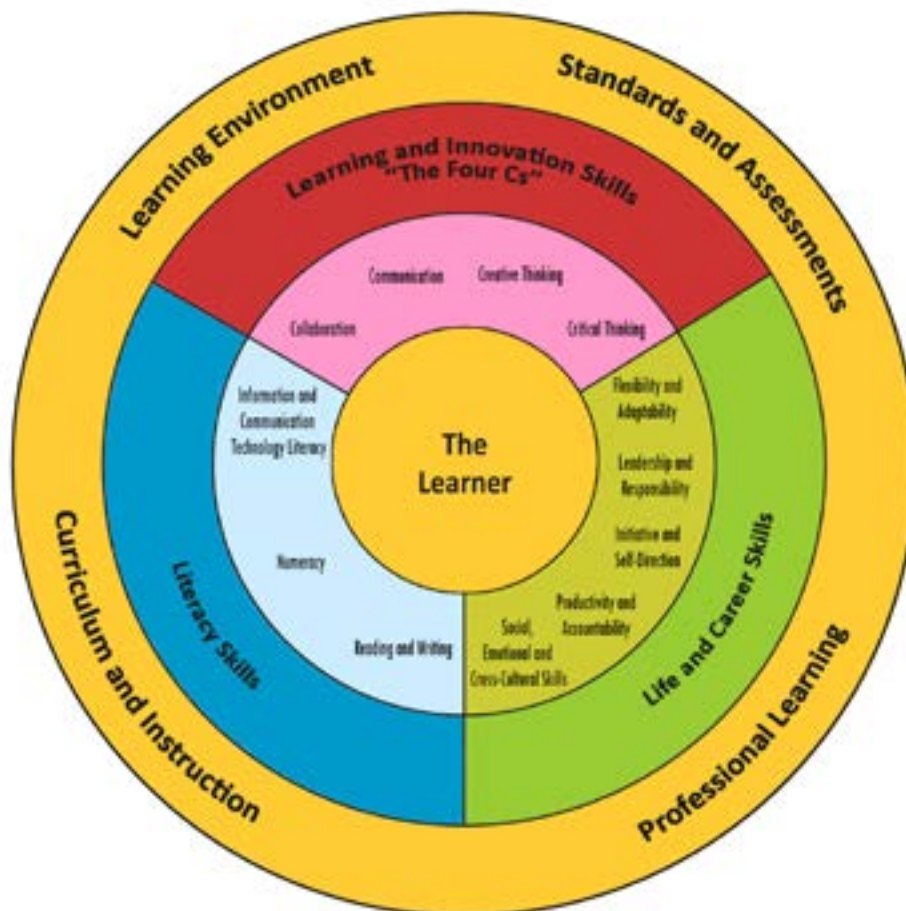

Support for students to develop these abilities and skills is important across curriculum areas and should be integrated into teaching, learning, and assessment strategies. Opportunities for integration of these skills and abilities should be planned with engaging and experiential activities that support the gradual release of responsibility model. For example, lessons in a variety of content areas can be infused with learning skills for Generation Next by using open-ended questioning, role plays, inquiry approaches, self-directed learning, student role rotation, and Internet-based technologies.

All programs have a shared responsibility in developing students' capabilities within all three skill areas.

## Education for Sustainable Development

*Sustainable development is defined as “development that meets the needs of the present without compromising the ability of future generations to meet their own needs”. (Our Common Future, 43)*

Sustainable development is comprised of three integrally connected areas: economy, society, and environment.

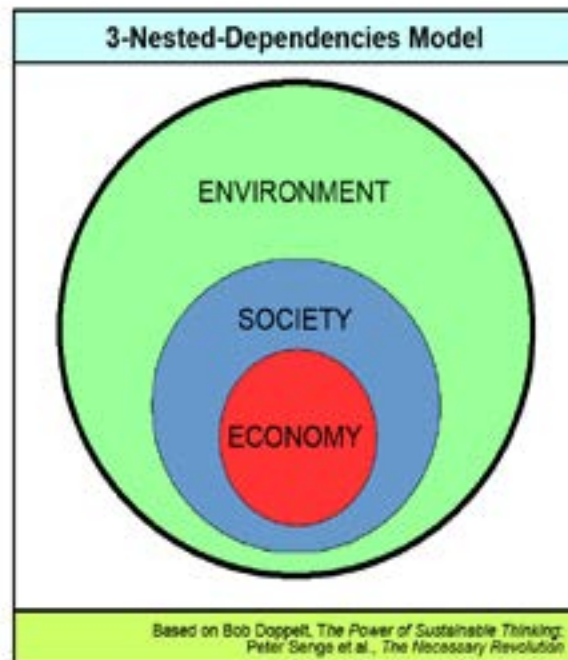

As conceived by the United Nations Educational, Scientific, and Cultural Organization (UNESCO) the overall goal of Education for Sustainable Development (ESD) is to integrate the knowledge, skills, values, and perspectives of sustainable development into all aspects of education and learning. Changes in human behaviour should create a more sustainable future that supports environmental integrity and economic viability, resulting in a just society for all generations.

ESD involves teaching *for* rather than teaching *about* sustainable development. In this way students develop the skills, attitudes, and perspectives to meet their present needs without compromising the ability of future generations to meet their needs.

Within ESD, the knowledge component spans an understanding of the interconnectedness of our political, economic, environmental, and social worlds, to the role of science and technology in the development of societies and their impact on the environment. The skills necessary include being able to assess bias, analyze consequences of choices, ask questions, and solve problems. ESD values and perspectives include an appreciation for the interdependence of all life forms, the importance of individual responsibility and action, an understanding of global issues as well as local issues in a global context. Students need to be aware that every issue has a history, and that many global issues are linked.

# Assessment and Evaluation

## Assessment

Assessment is the process of gathering information on student learning.

How learning is assessed and evaluated and how results are communicated send clear messages to students and others about what is valued.

Assessment instruments are used to gather information for evaluation. Information gathered through assessment helps teachers determine students' strengths and needs, and guides future instruction.

Teachers are encouraged to be flexible in assessing student learning and to seek diverse ways students might demonstrate what they know and are able to do.

Evaluation involves the weighing of the assessment information against a standard in order to make a judgement about student achievement.

Assessment can be used for different purposes:

1. Assessment *for* learning guides and informs instruction.
2. Assessment *as* learning focuses on what students are doing well, what they are struggling with, where the areas of challenge are, and what to do next.
3. Assessment *of* learning makes judgements about student performance in relation to curriculum outcomes.

### 1. *Assessment for Learning*

Assessment *for* learning involves frequent, interactive assessments designed to make student learning visible. This enables teachers to identify learning needs and adjust teaching accordingly.

Assessment *for* learning is not about a score or mark; it is an ongoing process of teaching and learning:

- Pre-assessments provide teachers with information about what students already know and can do.
- Self-assessments allow students to set goals for their own learning.
- Assessment *for* learning provides descriptive and specific feedback to students and parents regarding the next stage of learning.
- Data collected during the learning process from a range of tools enables teachers to learn as much as possible about what a student knows and is able to do.

## 2. *Assessment as Learning*

*Assessment as learning* involves students' reflecting on their learning and monitoring their own progress. It focuses on the role of the student in developing metacognition and enhances engagement in their own learning. Students can

- analyze their learning in relation to learning outcomes,
- assess themselves and understand how to improve performance,
- consider how they can continue to improve their learning, and
- use information gathered to make adaptations to their learning processes and to develop new understandings.

## 3. *Assessment of Learning*

*Assessment of learning* involves strategies designed to confirm what students know in terms of curriculum outcomes. It also assists teachers in determining student proficiency and future learning needs. *Assessment of learning* occurs at the end of a learning experience and contributes directly to reported results. Traditionally, teachers relied on this type of assessment to make judgements about student performance by measuring learning after the fact and then reporting it to others. Used in conjunction with the other assessment processes previously outlined, *assessment of learning* is strengthened. Teachers can

- confirm what students know and can do;
- report evidence to parents/guardians, and other stakeholders, of student achievement in relation to learning outcomes; and
- report on student learning accurately and fairly using evidence obtained from a variety of contexts and sources.

## *Involving Students in the Assessment Process*

Students should know what they are expected to learn as outlined in the specific curriculum outcomes of a course as well as the criteria that will be used to determine the quality of their achievement. This information allows students to make informed choices about the most effective ways to demonstrate what they know and are able to do.

It is important that students participate actively in assessment by co-creating criteria and standards which can be used to make judgements about their own learning. Students may benefit from examining various scoring criteria, rubrics, and student exemplars.

Students are more likely to perceive learning as its own reward when they have opportunities to assess their own progress. Rather than asking teachers, "What do you want?", students should be asking themselves questions:

- What have I learned?
- What can I do now that I couldn't do before?
- What do I need to learn next?

Assessment must provide opportunities for students to reflect on their own progress, evaluate their learning, and set goals for future learning.



## *Assessment Tools*

In planning assessment, teachers should use a broad range of tools to give students multiple opportunities to demonstrate their knowledge, skills, and attitudes. The different levels of achievement or performance may be expressed as written or oral comments, ratings, categorizations, letters, numbers, or as some combination of these forms.

The grade level and the activity being assessed will inform the types of assessment tools teachers will choose:

Anecdotal Records	Photographic Documentation
Audio/Video Clips	Podcasts
Case Studies	Portfolios
Checklists	Presentations
Conferences	Projects
Debates	Questions
Demonstrations	Quizzes
Exemplars	Role Plays
Graphic Organizers	Rubrics
Journals	Self-assessments
Literacy Profiles	Tests
Observations	Wikis

## *Assessment Guidelines*

Assessments should measure what they intend to measure. It is important that students know the purpose, type, and potential marking scheme of an assessment. The following guidelines should be considered:

- Collect evidence of student learning through a variety of methods; do not rely solely on tests and paper and pencil activities.
- Develop a rationale for using a particular assessment of learning at a specific point in time.
- Provide descriptive and individualized feedback to students.
- Provide students with the opportunity to demonstrate the extent and depth of their learning.
- Set clear targets for student success using learning outcomes and assessment criteria.
- Share assessment criteria with students so that they know the expectations.

## *Evaluation*

Evaluation is the process of analyzing, reflecting upon, and summarizing assessment information, and making judgements or decisions based on the information gathered. Evaluation is conducted within the context of the outcomes, which should be clearly understood by learners before teaching and evaluation take place. Students must understand the basis on which they will be evaluated and what teachers expect of them.

During evaluation, the teacher interprets the assessment information, makes judgements about student progress, and makes decisions about student learning programs.

---

## Section Two: Curriculum Design

### Rationale

The vision of science education in Newfoundland and Labrador is to develop scientific literacy.

*Scientific literacy is an evolving combination of the science-related attitudes, skills, and knowledge students need to develop inquiry, problem solving, and decision making abilities; to become lifelong learners; and to maintain a sense of wonder about the world around them.*

To develop scientific literacy, students require diverse learning experiences which provide opportunities to explore, analyze, evaluate, synthesize, appreciate, and understand the interrelationships among science, technology, society, and the environment that will affect their personal lives, careers, and futures.

Science education which strives for scientific literacy must engage students in science inquiry, problem solving, and decision making.

### *Science Inquiry*

Science inquiry involves posing questions and developing explanations for phenomena. While there is general agreement that there is no such thing as “the” scientific method, students require certain skills to participate in the activities of science. Skills such as questioning, observing, inferring, predicting, measuring, hypothesizing, classifying, designing experiments, collecting data, analyzing data, and interpreting data are fundamental to engaging in science. These skills are often represented as a cycle which involves the posing of questions, the generation of possible explanations, and the collection of evidence to determine which of these explanations is most useful in accounting for the phenomenon under investigation. Teachers should engage students in science inquiry activities to develop these skills.

### *Problem Solving*

Problem solving involves seeking solutions to human problems. It may be represented as a cycle consisting of the proposing, creating, and testing of prototypes, products, and techniques in and attempt to reach an optimum solution to a given problem. The skills involved in this cycle facilitate a process which has different aims and procedures from science inquiry. Students should be given opportunities to propose, perform, and evaluate solutions to problem solving or technological tasks.

### *Decision Making*

Decision making involves determining what we should do in a particular context or in response to a given situation. Increasingly, the types of problems that we deal with, both individually and collectively, require an understanding of the processes and products of science and technology. The process of decision making involves identification of the problem or situation, generation of possible solutions or courses of action, evaluation of the alternatives, and a thoughtful decision based on the information available. Students should be actively involved in decision making situations. While important in their own right, decision making situations also provide a relevant context for engaging in science inquiry and /or problem solving.

# Curriculum Outcomes Framework

## *General Curriculum Outcomes*

The foundation of the curriculum outcomes framework are the general curriculum outcomes (GCOs). Four general curriculum outcomes have been identified to delineate the four critical aspects of students' scientific literacy: science, technology, society, and the environment (STSE), skills, knowledge, and attitudes. These four GCOs are common to all science courses.

### **GCO 1: Science, Technology, Society, and the Environment**

Students will develop an understanding of the nature of science and technology, of the relationships between science and technology, and of the social and environmental contexts of science and technology.

### **GCO 2: Skills**

Students will develop the skills required for scientific and technological inquiry, for solving problems, for communicating scientific ideas and results, for working collaboratively, and for making informed decisions.

### **GCO 3: Knowledge**

Students will construct knowledge and understandings of concepts in life science, physical science, and Earth and space science, and apply these understandings to interpret, integrate, and extend their knowledge.

### **GCO 4: Attitudes**

Students will be encouraged to develop attitudes that support the responsible acquisition and application of scientific and technological knowledge to the mutual benefit of self, society, and the environment.

*Key Stage Curriculum Outcomes*

Key stage curriculum outcomes (KSCOs) align with the GCOs and summarize what students are expected to know and be able to do by the end of Grade 12.

## GCO 1 – STSE

By the end of grade 12, students will be expected to...

- describe and explain disciplinary and interdisciplinary processes used to enable us to understand natural phenomena and develop technological solutions
- distinguish between science and technology in terms of their respective goals, products, and values, and describe the development of scientific theories and technologies over time
- analyze and explain how science and technology interact with and advance one another
- analyze how individuals, society, and the environment are interdependent with scientific and technological endeavours
- evaluate social issues related to the application and limitations of science and technology, and explain decisions in terms of advantages and disadvantages for sustainability, considering a variety of perspectives

## GCO 2 – Skills

By the end of grade 12, students will be expected to

- ask questions about observed relationships and plan investigations of questions, ideas, problems, and issues
- conduct investigations into relationships between and among observable variables, and use a broad range of tools and techniques to gather and record data and information
- analyze data and apply mathematical and conceptual models to develop and assess possible explanations
- work as a member of a team in addressing problems, and apply the skills and conventions of science in communicating information and ideas and in assessing results

## GCO 3 – Knowledge

By the end of grade 12, students will be expected to

- analyze and describe relationships between force and motion
- analyze interactions within systems, using the laws of conservation of energy and momentum
- predict and explain interactions between waves and with matter, using the characteristics of waves
- explain the fundamental forces of nature, using the characteristics of gravitational, electric, and magnetic fields
- analyze and describe different means of energy transmission and transformation

## GCO 4 - Attitudes

By the end of grade 12, students will be expected to

- value the role and contribution of science and technology in our understanding of phenomena that are directly observable and those that are not
- appreciate that the applications of science and technology can raise ethical dilemmas
- value the contributions to scientific and technological development made by women and men from many societies and cultural backgrounds
- show a continuing and more informed curiosity and interest in science and science-related issues
- acquire, with interest and confidence, additional science knowledge and skills, using a variety of resources and methods, including formal research
- consider further studies and careers in science- and technology-related fields
- confidently evaluate evidence and consider alternative perspectives, ideas, and explanations
- use factual information and rational explanations when analysing and evaluating
- value the processes for drawing conclusions
- work collaboratively in planning and carrying out investigations, as well as in generating and evaluating ideas
- have a sense of personal and shared responsibility for maintaining a sustainable environment
- project the personal, social, and environmental consequences of proposed action
- want to take action for maintaining a sustainable environment
- show concern for safety and accept the need for rules and regulations
- be aware of the direct and indirect consequences of their actions

*Specific Curriculum Outcomes*

Specific curriculum outcomes (SCOs) align to KSCOs and GCOs and describe what students should know and be able to do at the end of each course. They are intended to serve as the focus for the design of learning experiences and assessment tasks. SCOs are organized into units for each science course.

## Course Overview

SCOs for Physics 2204 have been organized into five units:

- Integrated Skills
- Kinematics
- Dynamics
- Work and Energy
- Waves

Note, the Integrated Skills unit (Unit i) is not intended to be taught as a separate, stand alone unit.

## Suggested Yearly Plan

The order in which the units are presented in the curriculum guide is the recommended sequence.

Unit 1 - Kinematics

Unit 2 - Dynamics

Unit 3 - Work and Energy

Unit 4 - Waves

September	October	November	December	January	February	March	April	May	June	
<b>Unit 1: Kinematics</b>	<b>Unit 2: Dynamics</b>				<b>Unit 3: Work and Energy</b>			<b>Unit 4: Waves</b>		
<b>Skills Integrated Throughout</b>										

# How to Use the Four Column Curriculum Layout

## Outcomes

Column one contains specific curriculum outcomes (SCO) and accompanying delineations where appropriate. The delineations provide specificity in relation to key ideas.

Outcomes are numbered in ascending order

Delineations are indented and numbered as a subset of the originating SCO.

All outcomes are related to general curriculum outcomes.

## Focus for Learning

Column two is intended to assist teachers with instructional planning. It also provides context and elaboration of the ideas identified in the first column.

This may include:

- references to prior knowledge
- clarity in terms of scope
- depth of treatment
- common misconceptions
- cautionary notes
- knowledge required to scaffold and challenge student's learning

## Sample Performance Indicator(s)

This provides a summative, higher order activity, where the response would serve as a data source to help teachers assess the degree to which the student has achieved the outcome.

Performance indicators are typically presented as a task, which may include an introduction to establish a context. They would be assigned at the end of the teaching period allocated for the outcome.

Performance indicators would be assigned when students have attained a level of competence, with suggestions for teaching and assessment identified in column three.

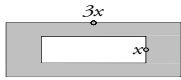
SPECIFIC CURRICULUM OUTCOMES	
<i>GCO 1: Represent algebraic expressions in multiple ways</i>	
<p><b>Outcomes</b></p> <p><i>Students will be expected to</i></p> <p>1.0 model, record and explain the operations of multiplication and division of polynomial expressions (limited to polynomials of degree less than or equal to 2) by monomials, concretely, pictorially and symbolically. [GCO 1]</p> <p>1.2 model division of a given polynomial expression by a given monomial concretely or pictorially and record the process symbolically.</p> <p>1.3 apply a personal strategy for multiplication and division of a given polynomial expression</p>	<p><b>Focus for Learning</b></p> <p>From previous work with number operations, students should be aware that division is the inverse of multiplication. This can be extended to divide polynomials by monomials. The study of division should begin with division of a monomial by a monomial, progress to a polynomial by a scalar, and then to division of a polynomial by any monomial.</p> <p>Division of a polynomial by a monomial can be visualized using area models with algebra tiles. The most commonly used symbolic method of dividing a polynomial by a monomial at this level is to divide each term of the polynomial by the monomial, and then use the exponent laws to simplify. This method can also be easily modelled using tiles, where students use the sharing model for division.</p> <p>Because there are a variety of methods available to multiply or divide a polynomial by a monomial, students should be given the opportunity to apply their own personal strategies. They should be encouraged to use algebra tiles, area models, rules of exponents, the distributive property and repeated addition, or a combination of any of these methods, to multiply or divide polynomials. Regardless of the method used, students should be encouraged to record their work symbolically. Understanding the different approaches helps students develop flexible thinking.</p> <p><b>Sample Performance Indicator</b></p> <p>Write an expression for the missing dimensions of each rectangle and determine the area of the walkway in the following problem:</p> <ul style="list-style-type: none"> <li>• The inside rectangle in the diagram below is a flower garden. The shaded area is a concrete walkway around it. The area of the flower garden is given by the expression <math>2x^2 + 4x</math> and the area of the large rectangle, including the walkway and the flower garden, is <math>3x^2 + 6x</math>.</li> </ul> 

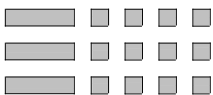

SPECIFIC CURRICULUM OUTCOMES	
<i>GCO 1: Represent algebraic expressions in multiple ways</i>	
<p><b>Sample Teaching and Assessment Strategies</b></p> <p>Teachers may use the following activities and/or strategies aligned with the corresponding assessment tasks:</p> <p>Modeling division using the sharing model provides a good transition to the symbolic representation. For example, <math>\frac{3x+12}{3} = \frac{3x}{3} + \frac{12}{3}</math>. To model this, students start with a collection of three <math>x</math>-tiles and 12 unit tiles and divide them into three groups.</p>  <p>For this example, <math>x + 4</math> tiles will be a part of each group, so the quotient is <math>x + 4</math>.</p> <p><b>Activation</b></p> <p>Students may</p> <ul style="list-style-type: none"> <li>Model division of a polynomial by a monomial by creating a rectangle using four <math>x^2</math>-tiles and eight <math>x</math>-tiles, where <math>4x</math> is one of the dimensions.</li> </ul> <p>Teachers may</p> <ul style="list-style-type: none"> <li>Ask students what the other dimension is and connect this to the symbolic representation.</li> </ul> <p><b>Connection</b></p> <p>Students may</p> <ul style="list-style-type: none"> <li>Model division of polynomials and determine the quotient</li> </ul> <p>(i) <math>(6x^2 + 12x - 3) \div 3</math></p> <p>(ii) <math>(4x^2 - 12x) \div 4x</math></p> <p><b>Consolidation</b></p> <p>Students may</p> <ul style="list-style-type: none"> <li>Draw a rectangle with an area of <math>36a^2 + 12a</math> and determine as many different dimensions as possible.</li> </ul> <p>Teachers may</p> <ul style="list-style-type: none"> <li>Discuss why there are so many different possible dimensions.</li> </ul> <p><b>Extension</b></p> <p>Students may</p> <ul style="list-style-type: none"> <li>Determine the area of one face of a cube whose surface area is represented by the polynomial <math>24s^2</math>.</li> <li>Determine the length of an edge of the cube.</li> </ul>	<p><b>Resources and Notes</b></p> <p><b>Authorized</b></p> <ul style="list-style-type: none"> <li><i>Math Makes Sense 9</i></li> <li>Lesson 5.5: Multiplying and Dividing a Polynomial by a Constant</li> <li>Lesson 5.6: Multiplying and Dividing a Polynomial by a Monomial</li> <li>ProGuide: pp. 35-42, 43-51</li> <li>CD-ROM: Master 5.23, 5.24</li> <li>See It Videos and Animations: <ul style="list-style-type: none"> <li>Multiplying and Dividing a Polynomial by a Constant, Dividing</li> <li>Multiplying and Dividing a Polynomial by a Monomial, Dividing</li> </ul> </li> <li>SB: pp. 241-248, 249-257</li> <li>PB: pp. 206-213, 214-219</li> </ul>

**Resources and Notes**

Column four references supplementary information and possible resources for use by teachers.

These references will provide details of resources suggested in column two and column three.

**Suggestions for Teaching and Assessment**

This column contains specific sample tasks, activities, and strategies that enable students to meet the goals of the SCOs and be successful with performance indicators. Instructional activities are recognized as possible sources of data for assessment purposes. Frequently, appropriate techniques and instruments for assessment purposes are recommended.

Suggestions for instruction and assessment are organized sequentially:

- Activation - suggestions that may be used to activate prior learning and establish a context for the instruction
- Connection - linking new information and experiences to existing knowledge inside or outside the curriculum area
- Consolidation - synthesizing and making new understandings
- Extension - suggestions that go beyond the scope of the outcome

These suggestions provide opportunities for differentiated learning and assessment.

# How to use a Strand overview

At the beginning of each strand grouping there is explanation of the focus for the strand and a flow chart identifying the relevant GCOs, KSCOs and SCOs.

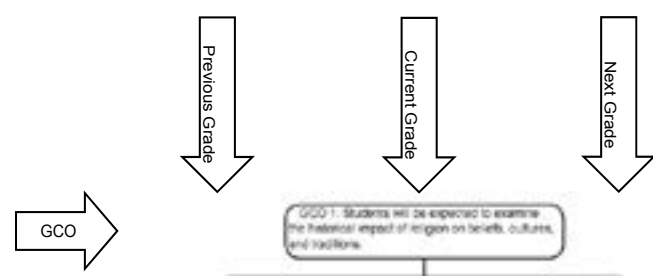
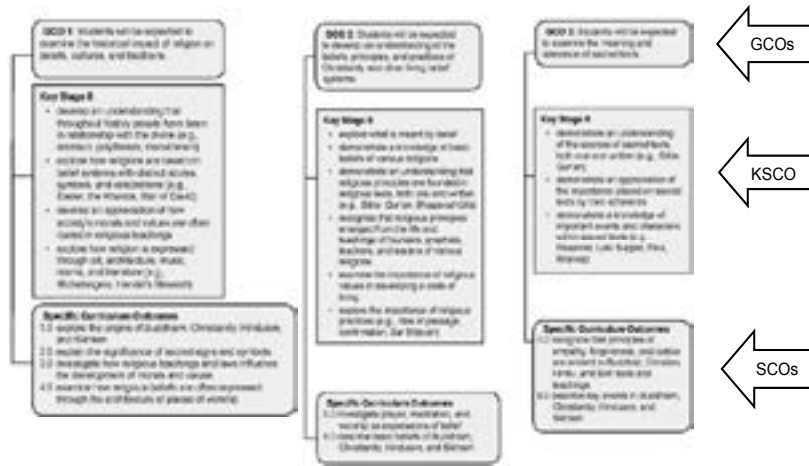

Grade 4	Grade 5	Grade 6
1.0 explore the origins of Judaism, Christianity, and Islam	1.0 explore the origins of Buddhism, Christianity, Hinduism, and Sikhism	1.0 explore the origins of Bahá'í Faith, Christianity, and Islam
2.0 explain the significance of religious traditions	2.0 explain the significance of sacred signs and symbols	2.0 examine stories of creation and the effects of religious spirituality, Christianity, and Islam
3.0 explore how teachings and laws of Christianity, Islam, and Judaism influence the development of norms and values	3.0 investigate how religious teachings and laws influence the development of norms and values	3.0 compare the teachings and laws of Christianity and Islam
	4.0 examine how religious beliefs are often expressed through the architecture of places of worship	4.0 examine how religious beliefs are often expressed through art, music, drama, and dance

The SCOs Continuum follows the chart to provide context for teaching and assessment for the grade/course in question. The current grade is highlighted in the chart.

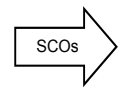

---

Section Three:  
Specific Curriculum Outcomes

Unit i - Integrated Skills

## Focus

Students use a variety of skills when investigating questions, ideas, problems, and issues. While these skills are not unique to science, they play an important role in the development of scientific understandings and in the application of science and technology to new situations.

The listing of skills is not intended to imply a linear sequence or to identify a single set of skills required in each science investigation. Every investigation has unique features that determine the particular mix and sequence of skills.

Four broad areas of skills are outlined and developed:

- Initiating and Planning - These are the skills of questioning, identifying problems, and developing initial ideas and plans.
- Performing and Recording - These are the skills of carrying out action plans, which involves gathering evidence by observation and, in most cases, manipulating materials and equipment.
- Analyzing and Interpreting - These are the skills of examining information and evidence, of processing and presenting data so that it can be interpreted, and interpreting, evaluating, and applying the results.
- Communication and Teamwork - In science, communication skills are essential at every stage where ideas are being developed, tested, interpreted, debated, and agreed upon. Teamwork skills are also important, since the development and application of science ideas is a collaborative process both in society and in the classroom.

Students should be provided with opportunities to develop and apply their skills in a variety of contexts. These contexts connect to the STSE component of the curriculum by linking to three processes for skills application:

- Science inquiry - seeking answers to questions through experimentation and research
- Problem solving - seeking solutions to science-related problems by developing and testing prototypes, products, and techniques to meet a given need.
- Decision making - providing information to assist the decision making process.

## Unit i - Integrated Skills

Unit i, the *Integrated Skills* unit, appears at the beginning of this curriculum guide. A total of 43 different skill outcomes are identified and addressed throughout high school science courses, however, all skills do not appear in each course or content unit. In Physics 2204, students are expected to develop proficiency with respect to 26 skill outcomes listed in the outcomes framework.

## Outcomes Framework

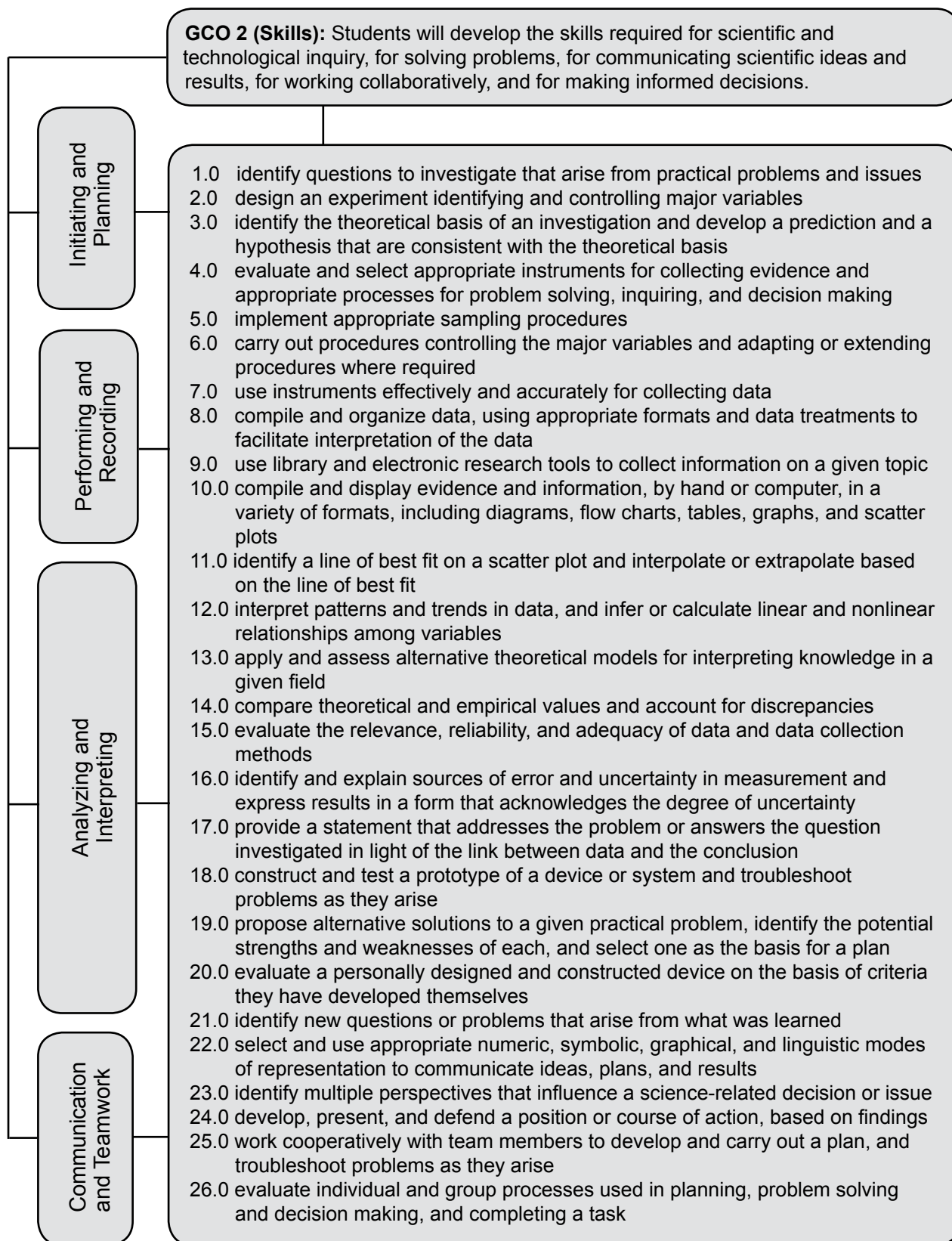

## SCO Skill Continuum

GCO 2 (Skills): Students will develop the skills required for scientific and technological inquiry, for solving problems, for communicating scientific ideas and results, for working collaboratively, and for making informed decisions.

Science 7-9	Science 10-12
<ul style="list-style-type: none"> <li>identify questions to investigate arising from practical problems and issues</li> <li>rephrase questions in a testable form and clearly define practical problems</li> <li>define and delimit questions and problems to facilitate investigation</li> </ul>	<ul style="list-style-type: none"> <li>identify questions to investigate that arise from practical problems and issues</li> </ul>
<ul style="list-style-type: none"> <li>design an experiment and identify major variables</li> </ul>	<ul style="list-style-type: none"> <li>design an experiment identifying and controlling major variables</li> </ul>
<ul style="list-style-type: none"> <li>state a prediction and a hypothesis based on background information or an observed pattern of events</li> </ul>	<ul style="list-style-type: none"> <li>identify the theoretical basis of an investigation and develop a prediction and a hypothesis that are consistent with the theoretical basis</li> </ul>
<ul style="list-style-type: none"> <li>select appropriate methods and tools for collecting data and information and for solving problems</li> </ul>	<ul style="list-style-type: none"> <li>evaluate and select appropriate instruments for collecting evidence and appropriate processes for problem solving, inquiring, and decision making</li> </ul>
	<ul style="list-style-type: none"> <li>implement appropriate sampling procedures</li> </ul>
<ul style="list-style-type: none"> <li>carry out procedures controlling the major variables</li> </ul>	<ul style="list-style-type: none"> <li>carry out procedures controlling the major variables and adapting or extending procedures where required</li> </ul>
<ul style="list-style-type: none"> <li>use instruments effectively and accurately for collecting data</li> </ul>	<ul style="list-style-type: none"> <li>use instruments effectively and accurately for collecting data</li> </ul>
<ul style="list-style-type: none"> <li>organize data using a format that is appropriate to the task or experiment</li> </ul>	<ul style="list-style-type: none"> <li>compile and organize data, using appropriate formats and data treatments to facilitate interpretation of the data</li> </ul>
	<ul style="list-style-type: none"> <li>use library and electronic research tools to collect information on a given topic</li> </ul>
<ul style="list-style-type: none"> <li>compile and display data, by hand or computer, in a variety of formats</li> </ul>	<ul style="list-style-type: none"> <li>compile and display evidence and information, by hand or computer, in a variety of formats, including diagrams, flow charts, tables, graphs, and scatter plots</li> </ul>
<ul style="list-style-type: none"> <li>predict the value of a variables by interpolating and extrapolating from graphical data</li> <li>identify the line of best fit on a scatter plot and interpolate or extrapolate on the line of best fit</li> <li>interpret patterns and trends in data, and infer and explain relationships among the variables</li> </ul>	<ul style="list-style-type: none"> <li>identify a line of best fit on a scatter plot and interpolate or extrapolate based on the line of best fit</li> <li>interpret patterns and trends in data, and infer or calculate linear and nonlinear relationships among variables</li> </ul>

## SCO Skill Continuum

Science 7-9	Science 10-12
	<ul style="list-style-type: none"> <li>• apply and assess alternative theoretical models for interpreting knowledge in a given field</li> </ul>
<ul style="list-style-type: none"> <li>• calculate theoretical values of a variable</li> </ul>	<ul style="list-style-type: none"> <li>• compare theoretical and empirical values and account for discrepancies</li> </ul>
<ul style="list-style-type: none"> <li>• identify the strengths and weaknesses of different methods of collecting and displaying data</li> </ul>	<ul style="list-style-type: none"> <li>• evaluate the relevance, reliability, and adequacy of data and data collection methods</li> </ul>
<ul style="list-style-type: none"> <li>• identify, and suggest explanations for, discrepancies in data</li> </ul>	<ul style="list-style-type: none"> <li>• identify and explain sources of error and uncertainty in measurement and express results in a form that acknowledges the degree of uncertainty</li> </ul>
<ul style="list-style-type: none"> <li>• state a conclusion, based on experimental data, and explain how evidence gathered supports or refutes an initial idea</li> <li>• identify and evaluate potential applications of findings</li> </ul>	<ul style="list-style-type: none"> <li>• provide a statement that addresses the problem or answers the question investigated in light of the link between data and the conclusion</li> </ul>
<ul style="list-style-type: none"> <li>• test the design of a constructed device or system</li> <li>• propose alternative solutions to a practical problem, select one, and develop a plan</li> <li>• identify and correct practical problems in the way a prototype or constructed device functions</li> <li>• evaluate designs and prototypes in terms of function, reliability, safety, efficiency, use of materials, and impact on the environment</li> </ul>	<ul style="list-style-type: none"> <li>• construct and test a prototype of a device or system and troubleshoot problems as they arise</li> <li>• propose alternative solutions to a given practical problem, identify the potential strengths and weaknesses of each, and select one as the basis for a plan</li> <li>• evaluate a personally designed and constructed device on the basis of criteria they have developed themselves</li> </ul>
<ul style="list-style-type: none"> <li>• identify new questions and problems that arise from what was learned</li> </ul>	<ul style="list-style-type: none"> <li>• identify new questions or problems that arise from what was learned</li> </ul>
<ul style="list-style-type: none"> <li>• communicate questions, ideas, intentions, plans, and results, using lists, notes in point form, sentences, data tables, graphs, drawings, oral language, and other means</li> </ul>	<ul style="list-style-type: none"> <li>• select and use appropriate numeric, symbolic, graphical, and linguistic modes of representation to communicate ideas, plans, and results</li> </ul>
	<ul style="list-style-type: none"> <li>• identify multiple perspectives that influence a science-related decision or issue</li> </ul>
<ul style="list-style-type: none"> <li>• defend a given position on an issue or problem, based on their findings</li> </ul>	<ul style="list-style-type: none"> <li>• develop, present, and defend a position or course of action, based on findings</li> </ul>
<ul style="list-style-type: none"> <li>• work cooperatively with team members to develop and carry out a plan, and troubleshoot problems as they arise</li> </ul>	<ul style="list-style-type: none"> <li>• work cooperatively with team members to develop and carry out a plan, and troubleshoot problems as they arise</li> </ul>
<ul style="list-style-type: none"> <li>• evaluate individual and group processes used in planning, problem solving and decision making, and completing a task</li> </ul>	<ul style="list-style-type: none"> <li>• evaluate individual and group processes used in planning, problem solving and decision making, and completing a task</li> </ul>







## Initiating and Planning

### Outcomes

*Students will be expected to*

- 1.0 identify questions to investigate that arise from practical problems and issues  
[GCO 2]

### Focus for Learning

Students should ask questions about observed relationships and plan investigations of questions, ideas, problems, and issues (p. 21). A number of skills aligned with this expectation are included in Physics 2204.

Science begins with a question. Scientific questions arise in a variety of ways. They can arise from

- curiosity about the natural and constructed world;
- personal observations of phenomena;
- examination of scientific models and theories, and their predictions;
- the findings of previous investigations;
- processes to find solutions to practical problems, or
- processes to reach a decision on a science-related issue.

Scientific questions differ from other types of questions in that their answers lie in explanations supported by empirical evidence (i.e., information acquired through observation and investigation).

Building on Science K-10 experiences, students should

- identify questions to investigate;
- phrase, or rephrase, questions in a testable form; and
- evaluate questions to determine if they are testable.

Often, the question to investigate is provided to students. To achieve this outcome, however, students must personally identify questions to investigate. They should, where possible, design and carry out the investigation to find answers to their identified question.

This outcome is addressed in the *Dynamics* unit, where students identify questions to investigate following analysis of safety features on motorized vehicles. The skill, however, should be addressed at every opportunity throughout the course.

Identifying a question to investigate is an initial step in starting a science fair project.

## Initiating and Planning

### Sample Teaching and Assessment Strategies

#### Activation

Teachers may

- Present information related to identifying a question or problem to investigate as part of a science fair project.

Students may

- Participate in a book walk through *Pearson Physics*. Locate the Quick Labs, Inquiry Labs, Problem Solving Labs, and Design a Labs and read the identified question or problem, where provided.

#### Connection

Teachers may

- Present high-interest, articles or videos about physics-related issues or problems (e.g., [explorecuriosity.org](http://explorecuriosity.org)) to generate questions to investigate.
- Model the identification of questions to investigate arising from problems and issues.
- Facilitate a discussion regarding criteria to use to determine if a question is testable.
- Present general “I Wonder” questions and ask students to rephrase them in a testable form (e.g., I wonder... How are work, time, and power are related?).

Students may

- Use a question matrix to generate initial questions.
- Record potential questions to investigate in a personal science journal that is updated regularly.
- Record inquiry questions in a KWL chart.
- Apply criteria to determine whether a question is testable within the constraints and limits of resources.

#### Consolidation

Students may

- Identify a question to investigate as part of a science fair project.
- Read or view science-related articles and videos and identify potential questions to investigate.
- Select a question to investigate that is related to the presented problem.

### Resources and Notes

#### Authorized

*Pearson Physics* (Student Resource [SR])

- pp. 864-866

## Initiating and Planning

### Outcomes

*Students will be expected to*

2.0 design an experiment identifying and controlling major variables  
[GCO 2]

3.0 identify the theoretical basis of an investigation and develop a prediction and a hypothesis that are consistent with the theoretical basis  
[GCO 2]

### Focus for Learning

Students have prior experience designing experiments to determine cause and effect relationships among variables. In Physics 2204, students should design experiments identifying and controlling major variables.

When planning investigations, students should

- identify and define the major variables (i.e., dependent, independent, and control variables);
- phrase the inquiry question to investigate (i.e., cause and effect);
- design an experiment to generate relevant data; and
- devise a procedure that controls potential confounding variables.

Additionally, students should evaluate the designs of others experiments to identify the inquiry question and major variables, and assess whether confounding variables are controlled.

This skill is specifically addressed in the *Kinematics* and *Dynamics* units. Students design experiments to determine acceleration due to gravity and investigate the law conservation of momentum for collisions in one dimension. Additional opportunities include designing experiments to investigate the law of conservation of energy and to determine the speed of sound in air.

Questions to investigate arise in a variety of ways, including from examination of scientific theories and their predictions. Students should identify the theoretical basis of investigations.

When designing investigations, research tools are used to obtain information and previous discoveries that might help answer the identified question. The theoretical basis should emerge from this background research and enable the development of a prediction and a hypothesis consistent with the theory.

The skill of predicting and hypothesizing was first introduced in Science 4 using “If..., then... because...” templates. Predictions specify what is expected to happen to the dependent variable when the independent variable is manipulated in an experiment (If..., then...). Hypotheses provide an explanation for the prediction (If..., then... because...). Students should develop predictions and hypotheses that are consistent with the theoretical basis, not simply based on observed patterns.

While specifically addressed in Unit 4, opportunities to address and assess this skill are numerous. Investigations, for example, related to Newton’s laws, law conservation of mass and energy, law conservation of momentum, Snell’s law, and the work-energy theorem provide students opportunities to identify the theoretical basis and develop predictions and hypotheses consistent with the theoretical basis.

## Initiating and Planning

### Sample Teaching and Assessment Strategies

### Resources and Notes

#### Activation

Teachers may

- Provide examples of visual representations of a science inquiry process. Ask students to note similarities in their stages.
- Distinguish between a prediction and a hypothesis.
- Remind student of experiments they designed in Science 1206 related to factors affecting the rate of chemical reactions. Ask students to identify their independent, dependent, and controlled variables, and to develop a predictions and a hypothesis consistent with collision theory.

#### Connection

Teachers may

- Model stating predictions and hypotheses consistent with theories.
- Provide questions to investigate and ask students to identify the independent and dependent variables, as well as confounding variables that would need to be controlled.
- Routinely ask students to state predictions and hypotheses prior to conducting investigations.
- Collaboratively design an experiment with students identifying and controlling major variables to model the skill.
- Review with students the process that a scientist may take in designing an experiment. This process typically does not follow a set “scientific method” - a very artificial process.

Students may

- Select an Inquiry Lab from *Pearson Physics*, identify the major variables and theoretical basis, and develop a prediction and a hypothesis consistent with theoretical basis.

#### Consolidation

Teachers may

- Provide questions to investigate and ask students to design experiments identifying and controlling major variables, as well as identifying the theoretical basis, and stating predictions and hypotheses consistent with the theoretical basis.

Students may

- Design an investigation identifying and controlling major variables as a science fair project, and include background information related to the theoretical basis for the investigation and a prediction and hypothesis consistent with the theory.

## Initiating and Planning

### Outcomes

*Students will be expected to*

4.0 evaluate and select appropriate instruments for collecting evidence and appropriate processes for problem solving, inquiring, and decision making [GCO 2]

5.0 implement appropriate sampling procedures [GCO 2]

### Focus for Learning

When planning investigation of questions, ideas, problems, and issues, students should evaluate and select instruments and processes appropriate for the task.

While students have prior experience with scientific inquiry, problem solving, and decision making processes, a general review of these processes is warranted.

With respect to instruments, students should evaluate alternatives and select the those most appropriate for the task. Given the context, for example, what are the most appropriate instruments to use to measure acceleration, angles, distance, force, mass, time, velocity?.

Often the instruments used in investigations are provided to meet the expectation of this outcome. Students must, however, evaluate and select appropriate instruments. Evaluation should include instrument precision and accuracy and consideration of both analog and digital instruments.

This skill is addressed in the *Work and Energy* unit. Students design and carry out an investigation of the law conservation of energy. They select appropriate instruments to measure gravitational potential and kinetic energies and calculate the percent efficiency of their system.

When planning investigations, developing appropriate sampling procedures (i.e., sample selection, measurement, and analysis procedures) is critical. Students developed sampling procedures in Science 1206. In Physics 2204, students should implement appropriate sampling procedures, when conducting investigations.

Determining what sample selection, measurement, and analysis procedures are appropriate for an investigation is a skill that develops gradually over time, as students are increasingly exposed to investigations from different disciplines. Adherence to standardized procedures ensures repeatability. Students should appropriately use instruments to meet specific sampling requirements. Instruments could include

- stop watch, recording timer and ticker tape;
- ruler, metre stick, tape measure, trundle wheel;
- protractor;
- spring scales of varying capacities, weigh scales, electronic balance; and
- motion, force, and magnetic field sensors.

This skill is addressed in the *Work and Energy* unit when students conduct an investigation to determine the spring constant,  $k$ , and discover Hooke's Law. Students develop and implement sampling procedures to measure spring stretch (e.g., instrument choice, measurement technique, number of measurements, analysis). Strict adherence to implementation of developed sampling procedures should result in precise and accurate data.

## Initiating and Planning

### Sample Teaching and Assessment Strategies

#### Activation

Teachers may

- Review scientific inquiry, problem-solving, and decision making processes.
- Distinguish between and provide examples of probability and non-probability sampling.

#### Connection

Teachers may

- Model evaluating and selecting appropriate instruments, for example, to measure distance and force.
- Where possible, provide a variety of instruments for students to choose from when collecting evidence, including both analogue and digital instruments.
- Demonstrate the capabilities and limitations of various instruments.

Students may

- Where applicable, analyze experimental procedures to describe the sampling procedures used and discuss whether they were appropriate.
- Collaboratively identify potential limitations of specific sampling instruments or procedures.

#### Consolidation

Students may

- Evaluate and select appropriate instruments and develop appropriate sampling procedures when planning an investigation (e.g., open or guided in-class investigations, science fair project).
- Develop appropriate sampling procedures to determine percent efficiency of a model roller coaster.

### Resources and Notes

#### Authorized

*Pearson Physics* (SR)

- pp. 864-866

## Performing and Recording

### Outcomes

*Students will be expected to*

6.0 carry out procedures controlling the major variables and adapting or extending procedures where required  
[GCO 2]

7.0 use instruments effectively and accurately for collecting data  
[GCO 2]

### Focus for Learning

Students should conduct investigations into relationships among observable variables, and use a broad range of tools and techniques to gather and record data and information (p. 21). A number of skills aligned with this expectation are included in Physics 2204.

A controlled experiment tests only one variable at a time, while keeping all other variables constant. This ensures that tests are valid and unbiased.

Occasionally, while conducting an experiment, a confounding variable, that has not been accounted for, is identified. Failure to isolate and control this variable will compromise the validity of results and conclusions. In these instances, students should adapt or extend procedures to ensure fair testing.

This skill outcome should be addressed whenever students carry out experiments, for example, when investigating the relationship between

- force, mass, and acceleration;
- distance, velocity, and time; and
- kinetic and potential energies.

When conducting investigations, students should use analog and digital data collection tools and instruments effectively and accurately. In each of the Physics 2204 units, instruments are used to collect data and information (e.g., stop watch, recording timer and ticker tape, ruler, metre stick, tape measure, trundle wheel, protractor, spring scale, weigh scale, electronic balance, motion, force, and magnetic field sensors).

Teachers should demonstrate proper techniques for effective use and measurement accuracy of different instruments, and discuss potential sources of error caused by improper use.

Students should assess the precision and accuracy of measuring instruments and, when required, calibrate instruments prior to use. When using analog instruments, measurements should be recorded using the correct number of significant digits (i.e., all certain digits plus one estimated digit).

This skill should be addressed whenever students use analog or digital instruments to collect data. Effective and accurate use will improve with practice.



## *Performing and Recording*

### **Sample Teaching and Assessment Strategies**

### **Resources and Notes**

#### **Activation**

Teachers may

- Demonstrate appropriate use of instruments such as a stop watch, recording timer and ticker tape, ruler, metre stick, tape measure, trundle wheel, protractor, spring scale, weigh scale, electronic balance, and motion, force, and magnetic field sensors, and discuss common errors.
- Differentiate between the accuracy and precision using measurements collected with a bathroom scale, as an example.
- Demonstrate parallax error when reading analog scales.

Students may

- Identify variables to control in an experiment.

#### **Connection**

Students may

- Demonstrate how to accurately use instruments such as a(n) recording timer and ticker tape, spring scale, electronic balance, motion sensors.
- View video of their group conducting experiments, assess whether variables were adequately controlled, and suggest improvements to the procedures.
- View video of their group collecting data and assess whether instruments were used accurately and effectively
- When using analog instruments, capture digital photos of measurements with a mobile device and enlarge the image to improve measurement accuracy and estimation of the first uncertain digit.

#### **Consolidation**

Teachers may

- Use direct observations to assess whether students carry out procedures controlling major variables during investigations and their ability to adapt and extend procedures where required.
- Assess student proficiency using data collection instruments during investigations and as part of lab tests. The accuracy of reported data may also be assessed.

Students may

- Describe accurate use of instruments in the procedure section of formal lab reports.

## Performing and Recording

### Outcomes

*Students will be expected to*

- 8.0 compile and organize data, using appropriate formats and data treatments to facilitate interpretation of the data  
[GCO 2]
- 9.0 use library and electronic research tools to collect information on a given topic  
[GCO 2]

### Focus for Learning

Students should compile and organize data, while conducting investigations of questions, ideas, problems, and issues. They should select and use formats and data treatments (e.g., charts, diagrams, lists, tables, log books, maps, observational journals, digital files) that facilitate interpretation and analysis of the data and information. A digital spread sheet, for example, could be used to compile and organize quantitative data, recorded using the appropriate number of significant digits and units.

When selecting formats and treatments, the most important criteria should be ease of future data interpretation.

This skill is addressed in the *Dynamics* unit. Students compile and organize data from an investigation of the relationship between force, mass, and acceleration. To facilitate interpretation and analysis of data, students could organize a table to record data and record values using the appropriate number of significant digits and units.

Each unit of Physics of 2204 provides additional opportunities to address and assess this performing and recording skill.

If different student groups select different formats and treatments to compile and organize similar data, students should evaluate the appropriateness of each with respect to ease of data interpretation.

Students should use a broad range of research inquiry tools and techniques to gather information when investigating questions, ideas, problems, and issues.

Review relevant acceptable use of library and electronic research tools, practices, and policies. Students will continue to develop practical skills necessary to evaluate the validity, reliability, and bias of a source. They should determine origin of material and check sources for age appropriateness, organized links, and important and accessible information. They should also be able to use advanced search techniques and keywords.

A review of citing, referencing, types of information, sources, and plagiarism may be necessary.

This skill could be addressed and assessed when exploring STSE outcomes and is of particular importance when conducting background research on a topic or question as part of a science project.

## Performing and Recording

### Sample Teaching and Assessment Strategies

#### Activation

Teachers may

- Review research and citing protocol.
- Invite a representative from Newfoundland and Labrador Public Libraries (NLPL) to provide an overview of their services and databases. Request library cards for students. Alternatively, the teacher librarian may provide an overview of school library and learning commons services.

Students may

- Discuss topics from previous science courses on which they or their classmates conducted research.
- Discuss the difference between a valid source and a reliable source when conducting research (i.e., a reliable source may not necessarily be valid).

#### Connection

Teachers may

- Discuss efficient ways to organize data (e.g., formats, significant digits, units) that aid future interpretation and analysis.
- Provide raw, unorganized data or information from an investigation and ask students to organize it in an appropriate format.

Students may

- Brainstorm alternative ways to compile and organize sets of data and information and discuss their advantages and disadvantages.

#### Consolidation

Teachers may

- Allow groups to compile and organize data in different ways. Then ask students to compare the utility of the different formats used.

Students may

- Use research inquiry to collect information on STSE issues.
- Use research inquiry to determine the theoretical basis of an investigation.
- Compile and organize data collected from in-class investigations and as part of a science project.
- Justify their use of a particular organizational format or data treatment.

### Resources and Notes

#### Authorized

*Pearson Physics* (SR)

- pp. 864-866, 872

## Analyzing and Interpreting

### Outcomes

*Students will be expected to*

10.0 compile and display evidence and information, by hand or computer, in a variety of formats, including diagrams, flow charts, tables, graphs, and scatter plots  
[GCO 2]

11.0 identify a line of best fit on a scatter plot and interpolate or extrapolate based on the line of best fit  
[GCO 2]

### Focus for Learning

Students are should analyze data and apply mathematical and conceptual models to develop and assess possible explanations (p. 21). A significant number of skills aligned with this expectation are included in Physics 2204.

Students should compile and display data and information from investigations in a variety of formats:

- Diagrams are used to symbolically represent information.
- Flow charts are used to represent a process.
- Tables organize data and information into labelled columns and rows.
- Graphs (e.g., bar, histogram, pictograph, line) help visualize relationships in data.
- Scatter plots are used to determine the degree of correlation between variables.

Students should select the most appropriate format to represent their data and information and, where possible, use digital technologies in their creation. Representations should be clear, concise, and include titles, headings, labels, scales, units, symbols, and numbers, where appropriate. Accurate representation of data and information is paramount to facilitate analysis and interpretation, identify patterns and trends, and infer or calculate relationships among variables.

This skill outcome could be addressed whenever students conduct investigations (e.g., work-energy theorem lab). Formats such as tables, graphs, and scatter plots are often the focus of this outcome. Displaying information in vector and free-body diagrams should also be a focus.

Students have experience, from previous science courses, identifying a line of best fit and interpolating or extrapolating based on that line.

A line of best fit (straight or curved) represents the trend in data. Students should make the smoothest curve possible, evenly balancing points that do not fit the curve above and below. Where a point is far off the line, an error may have been made. A dotted line should be used when extending the curve beyond the data set.

Interpolation is the process of estimating values between points within the data set. Extrapolation is estimating values beyond the limits of the data set. There is some risk of inaccuracy involved with both processes, because it is assumed that the trend continues between or beyond measured data points.

This skill could be addressed and assessed whenever students analyze and interpret scatter plots with an identified line of best fit.

## Analyzing and Interpreting

### Sample Teaching and Assessment Strategies

#### Connection

Teachers may

- Review appropriate use of diagrams, flow charts, tables, bar graphs, line graphs, and scatter plots.
- Instruct how to draw free body diagrams.
- Review how to draw a line of best fit on scatter plots and how to interpolate or extrapolate values based on the line.
- Set clear expectations for the construction of diagrams, tables, graphs, and scatter plots.
- Highlight and discuss common graphing errors (e.g., selecting inappropriate type of graph for the data, placing variables on wrong axes, inappropriate scaling, attempting to have the line of best fit go through all data points).

Students may

- Justify selection of a particular format to compile and display data from an investigation.

#### Consolidation

Teachers may

- Provide data compiled and organized from an investigation. Ask students to display the data in an appropriate format.
- Present students with scatter plots and ask them to identify the line of best fit and estimate values using interpolation and extrapolation.

Students may

- Construct vector and free body diagrams to display information.
- Draw a line of best fit by hand and compare with one generated using a digital tool, for the same data set.
- Compile and display data and information from class investigations and science projects using a variety of digital technologies.

### Resources and Notes

#### Authorized

*Pearson Physics (SR)*

- pp. 869-874

## Analyzing and Interpreting

### Outcomes

*Students will be expected to*

12.0 interpret patterns and trends in data, and infer or calculate linear and nonlinear relationships among variables  
[GCO 2]

13.0 apply and assess alternative theoretical models for interpreting knowledge in a given field  
[GCO 2]

### Focus for Learning

Students should analyze data and apply mathematical models to develop and assess possible explanations. Analyzing data includes interpreting trends and patterns, and inferring or calculating relationships.

- A trend is the general tendency of a data set to change. While individual data points may vary, the overall data trends in one direction.
- Patterns refer to data or information that repeat in a predictable way.
- Relationships are similar to trends, but have a clear mathematical relationship (e.g., linear relationship).

Identifying trends, patterns, and relationships requires accurate representation of data in tables, graphs, and scatter plots.

Students should infer linear (e.g., force of friction vs mass) and nonlinear relationships (e.g., kinetic energy of a particle [ $E_K = \frac{1}{2}mv^2$ ]) from data and representations.

For linear relationships, students should calculate slope and determine the equation of the line of best fit ( $y = mx + b$ ).

This skill could be addressed whenever students analyze and interpret data from investigations. Where possible, computers and digital tools should be used to enhance analysis and interpretation.

Theories are well supported explanations of phenomena. As new scientific investigations are conducted and new evidence is discovered, scientific theories may change. This may result in alternative theories with differing explanations. Scientists often debate differing explanations, inspiring further research and driving the quest for scientific knowledge.

Students should analyze and interpret knowledge and evidence using theoretical models, where appropriate. In Unit 4, students assess the wave model of light and the particle model of light.

## Analyzing and Interpreting

### Sample Teaching and Assessment Strategies

#### Connection

Teachers may

- Present exemplars of tables and graphs illustrating typical trends and patterns in data, and linear and non-linear relationships.
- Model interpreting patterns and trends in data and inferring or calculating linear and non-linear relationships among variables.

Students may

- Draw lines of best fit by hand and using digital tools.

#### Consolidation

Teachers may

- Present graphs and ask students to
  - explain what the graph is communicating,
  - interpolate and extrapolate information,
  - identify patterns or trends,
  - infer relationships among variables, and
  - calculate, where possible, linear and non-linear relationships.

Students may

- Interpret patterns and trends, and infer and calculate relationships, in data compiled and displayed as part of class investigations and science projects.

### Resources and Notes

#### Authorized

*Pearson Physics* (SR)

- pp. 872-874

## Analyzing and Interpreting

### Outcomes

*Students will be expected to*

14.0 compare theoretical and empirical values and account for discrepancies [GCO 2]

15.0 evaluate the relevance, reliability, and adequacy of data and data collection methods [GCO 2]

### Focus for Learning

Empirical values are measures collected from observations or investigations. Theoretical values are accepted values that have been determined by thorough, repeated investigation (e.g.,  $3.0 \times 10^8$  m/s is the theoretical value of the speed of light).

Where possible, students should compare their experimental values with the known values, calculate percentage error, and account for any discrepancies identified. Accounting for discrepancies is a critical, reflective practice through which students identify sources of error and suggest modifications to improve the investigation.

In the *Kinematics* unit, students conduct a guided investigation to determine acceleration due to gravity of a falling object. The accepted theoretical value is  $9.8 \text{ m/s}^2$  for objects dropped near Earth's surface and in the absence of air resistance. Students should compare their calculated value with the known value, calculate percentage error, and account for any discrepancy identified. Most discrepancies can be explained by confounding variables and/or procedural and measurement errors. Students should suggest changes to their investigation and measurement procedures to mitigate error and improve the accuracy of their empirical value.

Large percentage errors provide significant opportunities to reflect on investigative processes and skills.

Students should evaluate data and data collection methods with respect to

- relevance (i.e., Does the collected data help answer the initial question?);
- reliability (i.e., Can the data and findings be replicated?); and
- adequacy (i.e., Is the quality and quantity of the data sufficient to draw a conclusion?).

This skill is applied in the *Work and Energy* unit. Students design and carry out an investigation to determine the spring constant and develop Hooke's Law. Students should evaluate their data and data collection methods with respect to relevance, reliability, and adequacy. Evaluation should consider sample size (e.g., the number of springs investigated, the number of measurements per spring, hanging masses used), sampling technique (e.g., What points were used to measure spring stretch?, Was parallax error avoided? What measurement tool was used? How many significant digits were used in data?), sample analysis (e.g., Were all measurements included in data, What statistical analysis was performed on data?), and relevance to question investigated.

Following evaluation, students should suggest modifications to the investigation to improve relevance, reliability, and adequacy of data and data collection methods.



## Analyzing and Interpreting

### Sample Teaching and Assessment Strategies

#### Activation

Teachers may

- Use political polling as the context to discuss sampling and the relevance, reliability, and adequacy of data and data collection methods. Discuss examples of inaccurate polling when compared to actual election results.

#### Connection

Teachers may

- Review what is meant by relevance, reliability, and adequacy of data and data collection methods.
- Model evaluating the data and data collection methods of student investigations and the published investigations of others.

Students may

- Discuss the relevance, reliability, and adequacy of data and data collection methods within the context of sample investigations.
- Measure the voltage of an unused 9 V battery. Compare the theoretical and empirical values and calculate percentage error.
- Calculate percentage error for an experimental value of acceleration due to gravity measured to be  $9.63 \text{ m/s}^2$ .
- Identify theoretical values from daily life and indicate reasons why observed values may differ from the theoretical value (e.g., the speed of a car).
- Reflect on major variables, experimental procedures, and measurement tools and techniques used, when attempting to account for discrepancies between theoretical and empirical values.

#### Consolidation

Students may

- Evaluate the relevance, reliability, and adequacy of data and data collection methods as part of their written conclusion in formal lab reports.
- View the procedures and findings of investigations, evaluate the relevance, reliability, and adequacy of data and data collection methods, and make suggestions for improvement.
- Suggest improvements to the data collection methods used by classmates in guided investigations and science projects.

### Resources and Notes

#### Authorized

*Pearson Physics* (SR)

- pp. 872-874

## Analyzing and Interpreting

### Outcomes

*Students will be expected to*

16.0 identify and explain sources of error and uncertainty in measurement and express results in a form that acknowledges the degree of uncertainty  
[GCO 2]

### Focus for Learning

Error and uncertainty exist in every measurement, but, with care and refinement of experimental methods, they can be reduced.

Students should identify and explain sources of error in measurements, including systematic and random errors.

Systematic errors consistently cause measurements to be too high or too low. They can be caused by

- faulty measurement tools and instruments (e.g., a mis-calibrated balance or force meter);
- inaccurate measurement tools and instruments (e.g., metre stick, stop watch); or
- incorrect use of measurement tools and instruments (e.g., human error measuring distance from the end of a ruler instead of the zero mark).

Systematic errors may be difficult to identify. Once identified, however, they can be eliminated. If a force meter, for example, can't be calibrated to zero due to wear and measures 2 N, then 2 N should be subtracted from all future measurements to reduce systematic error. Greater understanding of the limitations and proper use of different measurement tools and instruments may also reduce uncertainty and error.

Random error in measurement occurs without a pattern. When using a stopwatch to measure time, for example, sometimes the measurement will be less than the actual time and other times more than the actual time. Another example comes from reading scales on measurement tools and instruments and estimating the first uncertain digit. Estimates will sometimes be too high and other times too low. Random errors may be reduced by repeating trials and using average measurements or increasing sample size.

Students should express data and results in a form that acknowledges the degree of uncertainty. They should use the appropriate number of significant digits as indicated by the measuring device and apply significant digit rules in calculations. Rules for their use can be found in Appendix A. In Science 1206, students referred to these rules when expected to use them. In Physics 2204, however, students should apply the rules from memory.

Teachers should note that scientific notation is not addressed in the existing Mathematics program.

This outcome is specifically addressed in the *Dynamics* unit when investigating kinetic and static friction, however, the skill could be addressed and assessed whenever students perform measurements as part of investigations.

## Analyzing and Interpreting

### Sample Teaching and Assessment Strategies

#### Activation

Teachers may

- Demonstrate and discuss possible sources of error when measuring force with a force meter. Other measuring instruments to demonstrate could include bathroom scales, metre sticks, or stop watches.

#### Connection

Teachers may

- Differentiate between and provide examples of systematic and random errors.
- Provide rules for the use of significant digits and model their use when measuring and performing calculations.

Students may

- Identify examples of potential systematic and random errors to avoid when using specific measuring tools and instruments (e.g., force meter, bathroom scale, electronic balance, metre stick, stop watch)
- Describe how to appropriately use a specific measuring tool or instrument to reduce potential error.
- Record and view video of classmates conducting investigations to identify possible sources of error.
- Record values using the appropriate number of significant digits for the measurement tool or instrument used.
- Use a mobile device to capture images of measurements on analog scales. Enlarging the image aids estimation of the first uncertain digit.

#### Consolidation

Teachers may

- Require students to examine and comment on sources of error when writing conclusions for investigations.

Students may

- Identify and explain sources of error when conducting investigations (e.g., science project).
- Suggest ways to reduce systematic and random errors in investigations.

### Resources and Notes

#### Authorized

*Pearson Physics* (SR)

- pp. 872-874

Appendices

- Appendix A

## Analyzing and Interpreting

### Outcomes

*Students will be expected to*

17.0 provide a statement that addresses the problem or answers the question investigated in light of the link between data and the conclusion  
[GCO 2]

18.0 construct and test a prototype of a device or system and troubleshoot problems as they arise  
[GCO 2]

### Focus for Learning

Following data analysis, students should develop possible explanations for the trends, patterns, and relationships identified and draw conclusions. Conclusions should

- be based on data analysis;
- relate to the hypothesis and indicate whether it is supported or refuted;
- compare the results obtained with those expected;
- examine and comment on sources of error and uncertainty;
- assess the effectiveness of the investigative design;
- indicate how results support the conclusion; and
- suggest possible applications of the findings, or how the question could be investigated further.

This skill outcome could be addressed and assessed whenever students perform investigations of questions, ideas, problems, and issues. Require detailed conclusions be included in formal lab reports.

Science starts with a question. Engineering starts with a problem.

Students have used engineering design (i.e., problem solving) processes in previous science courses and intermediate technology. However, a brief review of a typical process is warranted.

In the *Dynamics* unit, students should apply their knowledge of momentum, impulse and collisions to construct, for example, a device, incorporating a crumple zone, to protect an egg from breaking on impact with the floor when dropped.

Students should

- clearly define the problem to solve (e.g., constraints, success criteria);
- brainstorm or research possible solutions to the problem;
- evaluate potential tools and material for use;
- evaluate the strengths and weaknesses of possible solutions, collaboratively select a preferred solution, and construct a prototype;
- test and evaluate the prototype (testing may result in an unpromising solution being abandoned in favour of trying a different possible solution);
- modify the prototype for improvement and retest, iteratively, until a final solution is reached; and
- communicate the process followed and the final solution.

Troubleshooting problems as they arise and finding solutions is an integral part of the engineering design process.

## Analyzing and Interpreting

### Sample Teaching and Assessment Strategies

#### Activation

Teachers may

- Engage students in quick design challenges (e.g., spaghetti tower) to introduce the engineering design process.

Students may

- Recount prior experiences engaging in engineering design processes to construct prototypes.

#### Connection

Teachers may

- Provide a checklist of expectations for writing conclusions.
- Model drawing conclusions from investigations and provide exemplars of well written conclusions.
- Present images of various engineering design processes for comparison and analysis.
- Provide a variety of potential tools and construction materials for students to select and use in constructing prototypes.

Students may

- Pitch their personal solution to a design problem using sketches to communicate ideas.
- Keep detailed records of prototype construction plans, testing, and design modifications.

#### Consolidation

Teachers may

- Provide a formal lab report with the conclusion omitted. Ask students to write a conclusion for the report.

Students may

- Provide written conclusions for investigations conducted in class and science projects.
- Communicate final prototypes and share problems encountered during construction and how they were solved.

### Resources and Notes

#### Authorized

*Pearson Physics* (SR)

- p. 865

## Analyzing and Interpreting

### Outcomes

*Students will be expected to*

19.0 propose alternative solutions to a given practical problem, identify the potential strengths and weaknesses of each, and select one as the basis for a plan  
[GCO 2]

20.0 evaluate a personally designed and constructed device on the basis of criteria they have developed themselves  
[GCO 2]

21.0 identify new questions or problems that arise from what was learned  
[GCO 2]

### Focus for Learning

This skill relates to investigating problems and issues. As part of these processes, students should propose alternative solutions, identify the strengths and weaknesses of alternatives, and select a preferred solution to serve as the basis for a plan.

Students should collaboratively define the problem or issue, identify constraints, and establish evaluation criteria. Alternative solutions generally emerge from brainstorming, research, and identifying multiple perspectives. The use of graphic organizers may be helpful when identifying strengths and weaknesses of alternatives and evaluating them against criteria. The preferred solution should serve as the basis for a plan (i.e., course of action, design plan.)

In the *Work and Energy* unit, this critical thinking skill is applied when analyzing a science-related issue (e.g. alternative energies). The skill could also be applied in the *Dynamics* unit when constructing a device to protect an egg from impact.

In Science 7-9, students evaluated designs and prototypes in terms of function, reliability, safety, efficiency, use of materials, and impact on the environment. In Physics 2204, students should evaluate devices on the basis of personally developed criteria.

Students should establish design criteria requirements related to functions, attributes, and specifications, based on user identified need. The importance of these criteria can not be understated as they control the design of the device, throughout the engineering design process. Developing criteria may also include prioritizing criteria.

This skill outcome is addressed in the *Dynamics* unit, in conjunction with SCOs 18.0 and 19.0.

Science begins with a question or problem, and investigations gather data and information to help answer or solve them. Inevitably, what is learned, will lead to new questions or problems to investigate. Science is an iterative process. Initial questions or problems lead to successive investigations, but at deeper and deeper levels.

Students should identify new questions or problems to investigate from what is learned related to motion, dynamics, work and energy, and waves.

Routinely ask students to reflect on what was learned from investigations of questions, ideas, problems, and issues, and identify new questions or problems to investigate.

## *Analyzing and Interpreting*

### **Sample Teaching and Assessment Strategies**

### **Resources and Notes**

#### **Connection**

Teachers may

- Model proposing alternative solutions to problems.
- Present learning strategies (e.g., cost benefit analysis, consequence mapping) to use when identifying potential strengths and weaknesses of proposed alternatives.
- Routinely ask students to identify new questions or new problems from what was learned.

Students may

- Conduct research to identify alternative solutions to problems.
- Use graphic organizers (e.g., cost benefit matrix, PMI chart, t-chart) to compare the potential strengths and weakness of alternative solutions.
- Predict the outcome of selecting possible alternative solutions.
- Brainstorm and prioritize design criteria for constructed devices.
- Conduct focus groups to determine user criteria for a constructed device

#### **Consolidation**

Teachers may

- Require students include how to investigate a question or problem further when orally communicating findings of investigations and writing conclusions.

Students may

- Read formal lab reports and identify possible new questions to investigate that arise from the findings.
- Present final constructed devices with design criteria to classmates for evaluation. Evaluations should include suggestions for improvement.

## Communication and Teamwork

### Outcomes

*Students will be expected to*

22.0 select and use appropriate numeric, symbolic, graphical, and linguistic modes of representation to communicate ideas, plans, and results  
[GCO 2]

### Focus for Learning

Students should work as a member of a team when investigating questions and addressing problems, and apply the skills and conventions of science in communicating information and ideas and in assessing results (p. 21). A number of skills aligned with this expectation are included in Physics 2204.

Most scientists work in collaborative environments, surrounded by students and other scientists. Effective communication is critical and requires scientists and students to appropriately select and use numbers, symbols, diagrams, charts, tables, graphs, and oral and written language to communicate ideas, plans, and results.

Students should select use appropriate modes of representation to communicate ideas, plans and results, including

- accurate numeric representations using scientific notation and the appropriate number of significant digits when measuring, calculating, and investigating;
- symbolic representations such as vectors, constants, formulas, and units;
- diagrams such as vector diagrams, free body diagrams, prototype sketches, apparatus set up, flow charts, and labelled data and information tables;
- labelled graphs, scatter plots, and lines of best fit; and
- oral and written language (e.g., communicating aloud questions, ideas, thoughts, and intentions when investigating, writing conclusions and lab reports, presenting and defending a position or course of action).

Virtually every stage of inquiry, problem solving, and decision making processes (i.e., initiating and planning, performing and recording, analyzing and interpreting) involve communication.

This skill is specifically addressed in the *Dynamics* (i.e., using free body and vector diagrams to communicate results) and *Work and Energy* units (i.e., communicating the results of investigations demonstrating the law conservation of energy, or the relationships between kinetic and potential energies). The SCO, however, could be assessed whenever students use numbers, symbols, diagrams, charts, tables, graphs, and oral and written language to communicate.



## Communication and Teamwork

### Sample Teaching and Assessment Strategies

#### Activation

Teachers may

- Organize students in pairs and small groups, where possible, to encourage communication.

Students may

- Discuss what effective science communication looks and sound like.

#### Connection

Teachers may

- Request students digitally record their group communication when conducting investigations for assessment purposes. Recordings may be used for assessment of communication.
- Use checklists to assess student use of scientific terminology.
- Provide guidelines for creating formal lab reports.
- Review requirements for effective communication using diagrams, flow charts, tables, and graphs.
- Provide opportunities for groups to communicate findings in a format of their choosing. Then, compare and discuss the effectiveness of the different formats.
- Require students use appropriate numeric and symbolic representations when recording measures and performing calculations.

Students may

- Show workings to effectively communicate solutions when solving problems involving mathematical calculations.
- Represent the relative magnitude and direction of forces acting upon an object in a free body diagram.

#### Consolidation

Teachers may

- Assess student communication in data records, mathematical problem solving, vector and free body diagrams, constructed tables and graphs, oral presentations, and lab reports.

Students may

- Use appropriate modes of representation to communicate prototype plans, personally devised procedures, quantitative measurements, displays of findings, and conclusions.

### Resources and Notes

#### Authorized

*Pearson Physics* (SR)

- pp. 864-866

## Communication and Teamwork

### Outcomes

*Students will be expected to*

23.0 identify multiple perspectives that influence a science-related decision or issue  
[GCO 2]

24.0 develop, present, and defend a position or course of action, based on findings  
[GCO 2]

### Focus for Learning

Individuals may have strong feelings about scientific, technological, social, and environmental issues. Their perspective influences their position and decision on issues. Students should identify, seek to understand, and respect differing perspectives (e.g., cultural, economic, environmental, social, technical).

When analyzing science-related issues, students should identify relevant stakeholders (i.e., individuals or groups with an interest in or a concern about an issue) and their perspectives (i.e., How do they define or perceive the issue?, What assumptions do they make?, What are their values?). Understanding multiple perspectives is an essential component of effective communication and collaboration within problem solving and decision making processes.

This skill is specifically addressed in the *Dynamics* and *Work and Energy* units. Students should identify multiple perspectives when, for example, analyzing decisions regarding safety features in personal vehicle and development of large scale hydroelectricity projects or wind farms.

As part of problem solving and decision making processes, once students have evaluated alternatives and selected a preferred solution or position, the next step is to communicate the decision and take action. This often requires persuading others to act, including those with differing perspectives.

Students should develop a position or course of action regarding a science-related issue. In the *Work and Energy* unit, students develop, for example, a position in response to development of large scale hydroelectricity projects or wind farms. Students are further expected to present and defend the position. This could be facilitated through debate, role play, or formal presentations with follow up question and answer sessions.

Provide opportunities for students to develop, present, and defend personally held positions as well as assigned positions representing individuals or groups with differing perspectives.

Cross curricular connections could be made to English Language Arts outcomes related to communicating information and ideas effectively and clearly, and responding personally and critically.

## Communication and Teamwork

### Sample Teaching and Assessment Strategies

### Resources and Notes

#### Activation

Teachers may

- Discuss the multiple perspectives that influenced the historical acceptance of the scientific ideas of Galileo and led to his virtual house imprisonment.

#### Connection

Teachers may

- Model using an *Issues and Stakeholders* learning strategy ([explorecuriosity.org](http://explorecuriosity.org)) to identify the multiple perspectives influencing a science-related decision (e.g., whether to allowing offshore oil drilling in a marine protected area).
- Model adopting a position or developing a course of action, based on the findings of science investigations (e.g., use of autonomous vehicles).

Students may

- Brainstorm possible stakeholders and their perspectives when considering science-related decisions or issues.
- Use a cost benefit analysis matrix to compare alternative positions or courses of action.
- Use various sources to develop arguments in support of a position or course of action related to a decision or issue. Arguments may take the form of bulleted speaking points.

#### Consolidation

Students may

- Analyze a science-related issue and, based on findings, adopt a position statement or develop an action plan. Present the position or course action to an audience of peers and defend it.
- Adopt a specific stakeholder perspective and debate science-related decisions and issues with peers.
- Reflect on recent decisions regarding noteworthy science-related issues, identify multiple perspectives that may have influenced the decision, and draw conclusions regarding the degree of influence of differing perspectives. How might the decision have changed if scientific evidence was the greatest influence?
- Debate a current science-related issue, presenting evidence-based arguments, and be prepared to defend your position.

## Communication and Teamwork

### Outcomes

*Students will be expected to*

25.0 work cooperatively with team members to develop and carry out a plan, and troubleshoot problems as they arise  
[GCO 2]

26.0 evaluate individual and group processes used in planning, problem solving and decision making, and completing a task  
[GCO 2]

### Focus for Learning

Most scientists work in collaborative environments with other scientists, and capitalize on their specialized expertise. Cooperation and teamwork are essential skills for success in these environments.

Students should work collaboratively in science contexts. They should, for example,

- willingly work with others and accept assigned roles;
- communicate effectively, listen, and respond appropriately;
- seek other points of view and consider multiple perspectives;
- suspend personal views and objectively evaluate the ideas of others;
- provide and accept constructive criticism; and
- use procedures that enable everyone to participate.

While this skill is specifically addressed in the *Kinematics* unit, it can be assessed whenever students work in pairs or small groups to investigate questions, ideas, problems, and issues.

In Physics 2204, students engage in the processes of scientific inquiry, problem solving, and decisions making.

Students should reflect on and evaluate processes used, when working in pairs and small groups, to facilitate effective communication and teamwork. How did the group, for example,

- assign roles and responsibilities;
- ensure respectful communication;
- ensure individuals took responsibility for assigned tasks, errors made, and difficulties encountered;
- ensure equal participation of all individuals;
- ensure that the contributions of all individuals were valued;
- address conflict or differences of opinion; and
- enable everyone to participate in making decisions?

Students should evaluate their group as a whole and self evaluate their individual contribution to group activities. Additionally, they should identify processes and procedures that proved helpful in facilitating effective communication and teamwork and suggest others to implement in future activities.

This skill is specifically addressed in Unit 4. However, it can be assessed whenever students work in pairs or small groups to investigate questions, ideas, problems, and issues.

## *Communication and Teamwork*

### **Sample Teaching and Assessment Strategies**

#### **Activation**

Teachers may

- Organize students in pairs and small groups, where possible, to investigate questions, ideas, problems, and issues.

Students may

- Share prior positive and negative experiences related to group work and develop a set of best practices.

#### **Connection**

Teachers may

- Predetermine roles and responsibilities for groups to assign when carrying out tasks (e.g., manager/facilitator, recorder, presenter, questioner).

Students may

- View cooperative and collaborative group rubrics and create a list of essential characteristics.
- Collaboratively develop a rubric, based on best practices, to assess teamwork and compare with the norms of collaboration from English Language Arts curricula. Modify the rubric as deemed necessary.
- Actively seek the opinions of others when investigating.

#### **Consolidation**

Students may

- Engage in self evaluation of collaborative activities and suggest processes and procedures to improve future collaboration.
- Peer evaluate the collaboration which takes place in the science classroom. Use an agreed upon framework discussed within the group before the task is started.

### **Resources and Notes**

#### **Suggested**

- Appendix D: Guidelines for Collaboration (English Language Arts 2201 Curriculum Guide, p. 97)



---

Section Three:  
Specific Curriculum Outcomes  
Unit 1 - Kinematics

## Focus

Kinematics is the study of how objects move, and as such, makes up a large part of introductory physics.

Provide students varied experiences to explore kinematics. Experiences should include kinesthetic learning, where students feel the effects of different speeds and accelerations and see the difference these make in records of their own motion. Students should describe and explain displacement, velocity, and acceleration using various modes of representation and solve problems using graphical and algebraic analysis.

Opportunities to review science inquiry processes and address skill outcomes exist when students design and carry out a lab investigation to determine the type of motion an object undergoes when it rolls down an inclined ramp.

## Outcomes Framework

**GCO 2 (Skills):** Students will develop the skills required for scientific and technological inquiry, for solving problems, for communicating scientific ideas and results, for working collaboratively, and for making informed decisions.

- 2.0 design an experiment identifying and controlling major variables
- 7.0 use instruments effectively and accurately for collecting data
- 12.0 interpret patterns and trends in data, and infer or calculate linear and nonlinear relationships among variables
- 16.0 identify and explain sources of error and uncertainty in measurement and express results in a form that acknowledges the degree of uncertainty
- 25.0 work cooperatively with team members to develop and carry out a plan, and troubleshoot problems as they arise

**GCO 3 (Knowledge):** Students will construct knowledge and understandings of concepts in life science, physical science, and Earth and space science, and apply these understandings to interpret, integrate, and extend their knowledge.

- 27.0 use vectors to represent displacement, velocity, and acceleration
- 28.0 analyze quantitatively the horizontal or vertical motion of an object
- 29.0 identify the frame of reference for a given motion



**GCO 4 (Attitudes):** Students will be encouraged to develop attitudes that support the responsible acquisition and application of scientific and technological knowledge to the mutual benefit of self, society, and the environment.

*Students are encouraged to:*

- work collaboratively in planning and carrying out investigations, as well as in generating and evaluating ideas

# SCO Continuum

GCO 3 (Knowledge): Students will construct knowledge and understandings of concepts in life science, physical science, and Earth and space science, and apply these understandings to interpret, integrate, and extend their knowledge.

Science 1206	Physics 2204	Physics 3204
<ul style="list-style-type: none"> <li>• describe quantitatively the relationship among motion variables</li> <li>• analyze mathematically the relationship among displacement, velocity, and time</li> <li>• analyze graphically the relationship among displacement, velocity, and time for uniform and non-uniform motion</li> <li>• distinguish between instantaneous and average velocity</li> <li>• describe quantitatively the relationship among velocity, time, and acceleration</li> </ul>	<ul style="list-style-type: none"> <li>• use vectors to represent displacement, velocity, and acceleration</li> <li>• analyze quantitatively the horizontal or vertical motion of an object</li> <li>• identify the frame of reference for a given motion</li> </ul>	<ul style="list-style-type: none"> <li>• use vectors to represent force, velocity, and acceleration</li> <li>• identify the frame of reference for two-dimensional motion</li> <li>• analyze quantitatively the horizontal and vertical motion of a projectile</li> <li>• analyze quantitatively the two-dimensional motion in a horizontal plane and a vertical plane</li> <li>• describe uniform circular motion, using algebraic vector analysis</li> <li>• explain quantitatively circular motion using Newton’s laws</li> </ul>

## Suggested Unit Plan

September	October	November	December	January	February	March	April	May	June
<b>Unit 1: Kinematics</b>	<b>Unit 2: Dynamics</b>			<b>Unit 3: Work and Energy</b>			<b>Unit 4: Waves</b>		
<b>Skills Integrated Throughout</b>									

## Vectors

### Outcomes

*Students will be expected to*

27.0 use vectors to represent displacement, velocity, and acceleration  
[GCO 3]

### Focus for Learning

Prior to beginning Physics 2204, students should be proficient in unit conversion, scientific notation, and use of significant figures (i.e., significant digits). A brief review may be warranted. Students are expected to apply rules for significant digits in all measurements and calculations (Appendix A), without the aid of a reference sheet.

In Science 1206, students distinguished between scalar and vector quantities. In Physics 2204, they should use graphical and numeric methods to represent vector quantities such as displacement, velocity and acceleration. Compass directions should be limited to North, South, East, and West (i.e., no angles).

#### Graphically

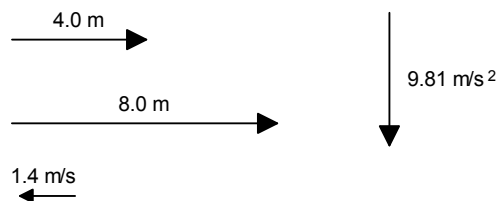

#### Numerically

$$\vec{v} = 2.0 \text{ m/s[E]} \quad \vec{d} = 17 \text{ m[N]} \quad \vec{a} = 0.65 \text{ m/s}^2 \text{ [W]}$$

Students should add and subtract vectors algebraically and graphically to solve problems

When adding vectors graphically, it should be emphasized that the resultant vector is obtained by drawing the vectors tip to tail. To subtract vectors, students should add the opposite vector tip to tail, rather than connecting vectors tail to tail.

Teachers may choose to address, in part, skill outcome 22.0 (i.e., select and use appropriate numeric, symbolic, graphical, and linguistic modes of representation to communicate ideas, plans, and results) using vector representations as the context. See the *Integrated Skills* unit for elaboration of this skill outcome.

#### Sample Performance Indicators

1. Describe the position, velocity, and acceleration vectors in a ball's path as it is tossed upwards and falls back down.
2. Draw vectors for velocity and acceleration for when a vehicle is speeding up and when it is slowing down.
3. An airplane travels 2109 km [W]. After a brief stopover, it travels 351 km [E]. Use a vector diagram to determine the displacement of the airplane. Verify your result algebraically.

## Vectors

### Sample Teaching and Assessment Strategies

#### Activation

Teachers may

- Facilitate a quiz-quiz-trade activity to review motion-related terminology from Science 1206 (e.g., scalar, vector, displacement, instantaneous velocity, acceleration, slope, non-uniform motion).

Students may

- Develop a treasure hunt with a list of vector-related instructions to find the “treasure” hidden within the school.
- Draw a motion diagram or a graph for an object accelerating and/or moving at a constant velocity.
- Use an online web mapping service (e.g., Google maps) to determine
  - the time it would take to walk around Central Park, New York; and
  - displacement, possible routes, and the fastest route to a location in your community (e.g., coffee shop). Compare actual times and distances for various routes with those indicated on the map.

#### Connection

Teachers may

- Provide velocity-time graphs. From the graph, ask students to determine displacement of the object (Graphs should show positive and negative areas).

Students may

- Describe one situation where velocity and acceleration are in the same direction and another where they are in opposite directions.

#### Consolidation

Teachers may

- Provide vectors for displacement, velocity, and acceleration, and ask students to describe the motion depicted (or vice versa).

Students may

- Carry out QuickLab 2-1 Taking a One-dimensional Vector Walk (*Pearson Physics*, p. 69).

#### Extension

Teachers may

- Use vectors to graphically represent simple uniform motion in two dimensions (tip-to-tail method).

### Resources and Notes

#### Authorized

*Pearson Physics Level 20*  
(Teacher Resource [TR])

- Unit I: Chapter 1 pp. 1-35
- Unit I: Chapter 2 pp. 1-8

*Pearson Physics* (Student Resource [SR])

- pp. 4-75

Appendices

- Appendix A

## Investigating Motion in One Dimension

### Outcomes

*Students will be expected to*

- 2.0 design an experiment identifying and controlling major variables [GCO 2]
- 7.0 use instruments effectively and accurately for collecting data [GCO 2]
- 12.0 interpret patterns and trends in data, and infer or calculate linear and nonlinear relationships among variables [GCO 2]
- 16.0 identify and explain sources of error and uncertainty in measurement and express results in a form that acknowledges the degree of uncertainty [GCO 2]
- 25.0 work cooperatively with team members to develop and carry out a plan, and troubleshoot problems as they arise [GCO 2]

### Focus for Learning

Students should, in pairs or small groups, design and carry out a guided investigation, using a motion sensor, to collect position-time, velocity-time, and acceleration-time data for an object as it rolls down a ramp.

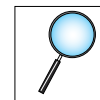

Working collaboratively, students should

- design the setup and procedure (e.g., equipment and materials required, slope of the ramp, position of sensor, start position, sampling procedures, software settings);
- carry out the investigation, controlling variables;
- collect data with the motion sensor and export it in a format that facilitates interpretation;
- generate graphs;
- infer and calculate relationships among variables; and
- identify sources of error and uncertainty.

To the largest extent possible, this lab should be student directed.

This initial lab investigation provides an opportunity to review science inquiry processes. Assess skill outcomes 2.0, 7.0, 12.0, 16.0, and 25.0 in conjunction with this lab investigation. Additionally, SCOs 5.0, 7.0, 8.0, 15.0, 16.0, 22.0, and 26.0 could be addressed and/or assessed. Refer to the *Integrated Skills* unit for elaboration of these outcomes.

Alternatively, this lab investigation could be carried out using a ticker tape timer.

### Attitude

Encourage students to work collaboratively in planning and carrying out investigations, and in generating and evaluating ideas. [GCO 4]

## *Investigating Motion in One Dimension*

### Sample Teaching and Assessment Strategies

#### Activation

Teachers may

- Provide examples of position-time and velocity-time graphs for interpretation.

Students may

- Create a diagram to represent a science inquiry process.

#### Connection

Teachers may

- Revisit the acceleration due to gravity guided investigation completed in Science 1206.

#### Consolidation

Students may

- Describe whether the relationship represented in each graph is linear or non-linear.
- Determine what type of motion is described by each graph.
- Suggest modifications to the lab setup and procedure that may reduce sources of error and uncertainty.

### Resources and Notes

#### Notes

The magnifying glass icon is used throughout the unit to indicate investigations.

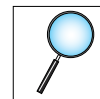

## Kinematics in One Dimension

### Outcomes

*Students will be expected to*

28.0 analyze quantitatively the horizontal or vertical motion of an object  
[GCO 3]

### Focus for Learning

Kinematics is a branch of classical mechanics that describes how objects move. Kinematics uses concepts such as distance, displacement, speed, velocity, acceleration, and time to describe the motion of objects.

In Science 1206, average acceleration was defined as the change in velocity of an object during a time interval.

$$\vec{a} = \frac{\vec{v}_2 - \vec{v}_1}{\Delta t}$$

Note, for uniformly accelerated motion, the instantaneous acceleration at any point in a time interval will be the same as the average acceleration for that time interval.

Remind students that the definition for acceleration above can be rearranged to solve for any other variable.

Additionally, in Science 1206, students related acceleration to the slope of a velocity-time graph and used the area under the graph to determine displacement. It is more efficient, however, to use equations when solving kinematics problems.

Show how the following kinematics equations are derived from a velocity-time graph of uniformly accelerated motion.

$$\Delta \vec{d} = \left( \frac{\vec{v}_1 + \vec{v}_2}{2} \right) \Delta t$$

$$\Delta \vec{d} = \vec{v}_1 \Delta t + \frac{1}{2} \vec{a} (\Delta t)^2$$

Another essential equation of kinematics can be derived using

the definition of acceleration and  $\Delta \vec{d} = \left( \frac{\vec{v}_1 + \vec{v}_2}{2} \right) \Delta t$ .

$$\vec{v}_2^2 = \vec{v}_1^2 + 2\vec{a}\Delta \vec{d}$$

A final equation students may find useful is  $\Delta \vec{d} = \vec{v}_2 \Delta t - \frac{1}{2} \vec{a} (\Delta t)^2$ .

Students are not expected to replicate any derivations.

Students should solve a variety of kinematics problems in one dimension. They should be able to solve for any variable in the applicable equation given the other values. Examples using the quadratic formula should be avoided in this course.

*Continued*



## *Kinematics in One Dimension*

### Sample Teaching and Assessment Strategies

#### **Activation**

Students may

- Carry out mini-investigations to determine fall time when dropping objects of different sizes and mass, from the same height.
- Design and play a Minute to Win It™ game involving motion variables.

#### **Connection**

Teachers may

- Present online videos of objects falling in a vacuum chamber. Discuss the limitations of kinematics equations in non-vacuum conditions.
- Present videos related to vehicle velocity and stopping distances as an application of kinematics.
- Present real life applications of kinematics equations (e.g., determining initial velocity at accident investigation sites from skid mark length and final resting point).

Students may

- Identify real life applications of kinematics equations.
- Relate personal experiences (e.g., sports, travel) to kinematics equations.
- Practice selecting an appropriate formula to solve kinematics problems.

### Resources and Notes

#### **Authorized**

*Pearson Physics Level 20 (TR)*

- Unit I: Chapter 1 pp. 26-33

*Pearson Physics (SR)*

- pp. 46-63

## Kinematics in One Dimension

### Outcomes

*Students will be expected to*

**28.0 analyze quantitatively the horizontal or vertical motion of an object [GCO 3]**

### Focus for Learning

Acceleration due to gravity was investigated in Science 1206. For problems involving free fall, students should note that

$$\vec{a} = \vec{g} = 9.81 \text{ m/s}^2 \text{ [down]}.$$

Define downwards as negative in free fall problems. Note, some resources provide examples defining downward as positive.

### Sample Performance Indicators

1. A car travelling 24 m/s can slow down at a rate of 8.0 m/s<sup>2</sup>. If an intersection is 41 m from the front of the vehicle when the brakes are applied, can the car stop before reaching the intersection?
2. A diver jumps vertically upwards at a velocity of 2.0 m/s. Rather than landing on the diving board, the diver misses and falls into the pool 7.0 m below.
  - What is the diver's velocity when they enter the water?
  - How long will it take the diver to hit the water?
3. A car travelling at 15 m/s accelerates at 2.0 m/s<sup>2</sup> for 3.0 seconds. How far does the car travel during this time interval?
4. An engineer is designing an airport runway. For the planes using the airport, the lowest acceleration rate is 3.0 m/s<sup>2</sup>. Starting from rest, the takeoff speed for a particular plane is 65 m/s. What is the minimum required length for the runway?

## Kinematics in One Dimension

### Sample Teaching and Assessment Strategies

#### Consolidation

Students may

- Investigate how an object behaves when dropped from rest at a given measured height. Record the time interval in each case and use the average time to determine the acceleration using the

$$\text{kinematics formula } \Delta \vec{d} = \left( \frac{\vec{v}_1 + \vec{v}_2}{2} \right) \Delta t.$$

- Solve problems related to the reaction time required for drivers to avoid hitting an obstacle a certain distance ahead, given braking acceleration, and initial velocity (e.g., 30 m/s initial velocity,  $-2.8 \text{ m/s}^2$  braking acceleration, and 200 m distance).
- Solve problems related to the distance necessary for a driver to avoid a collision with an obstacle at a certain distance ahead, given driver reaction time, initial velocity, and braking acceleration (e.g., 30 m/s initial velocity,  $-2.8 \text{ m/s}^2$  braking acceleration, and 1.0 s reaction time).

#### Extension

Teachers may

- Present two-object problems (e.g., Two cars approach each other on the highway. Given the velocities of the two cars, how long would it take for them to meet?) for students to solve. Extend this by introducing a non-uniform motion.

Students may

- Investigate and compare the time of fall for objects dropped from rest to those thrown straight upward or starting with an initial horizontal velocity.
- Research how aerial patrolled highways use highway markers and technology to determine vehicle speeds.

### Resources and Notes

#### Authorized

*Pearson Physics Level 20 (TR)*

- Unit I: Chapter 1 pp. 26-33

*Pearson Physics (SR)*

- pp. 46-63

## Relative Motion in One Dimension

### Outcomes

*Students will be expected to*

29.0 identify the frame of reference for a given motion  
[GCO 3]

### Focus for Learning

Students should understand that descriptions of motion depend on the frame of reference of the observer. Observers in different reference frames may measure different values for displacement, velocity, and acceleration, even though each observer is describing the motion of the same object. This is what is meant by relative motion. Various examples, such as a moving sidewalk, should be used to help students understand this concept.

It is also important to note that a moving medium, such as water or air, affects the motion of objects that are in that medium.

Students should solve one-dimensional relative motion problems under various conditions. Problems should include

- two objects travelling in the same direction,
- two objects travelling opposite directions, and
- an object moving relative to a medium that is moving relative to the ground (e.g., an airplane moving into a headwind or with a tailwind, a boat moving with or against the current, a person walking on a moving train).

Students should solve relative velocity and relative displacement problems. Additionally, they should solve relative motion problems

including time, using  $\vec{v} = \frac{\Delta \vec{d}}{\Delta t}$ .

Problems should include determining and comparing air travel time with a head or tailwind and sailing time with or against the current.

Students could solve relative motion problems using graphical (e.g., vector addition) or algebraic representations. Algebraic representation

requires the equation  ${}_o\vec{v}_g = {}_o\vec{v}_m + {}_m\vec{v}_g$ , where

${}_o\vec{v}_g$  is the velocity of the object relative to the ground,

${}_o\vec{v}_m$  is the velocity of the object relative to the medium, and

${}_m\vec{v}_g$  is the velocity of the medium relative to the ground.

After setting up the equation and substituting given values, students should be able to algebraically solve for any unknown.

*Continued*

## Relative Motion in One Dimension

### Sample Teaching and Assessment Strategies

Teachers may choose to address SCO 29.0 following SCO 27.0.

#### Activation

Teachers may

- Present the video *What Keeps us Stuck to the Earth* by the Perimeter Institute to introduce frames of reference.
- Demonstrate frame of reference by tossing a ball straight up in the air while stationary and while walking at a constant velocity. The motion of the ball can be compared from the frame of reference of a stationary student observer and the person walking (Despite introducing two-dimensional motion, the demonstration effectively illustrates the concept). Extend the demonstration by presenting videos of balls thrown from a moving car, which shows the path of the ball.
- Present the *2009 Chevy Malibu vs 1959 Bel Air Crash Test* youtube video. At time stamp 0:50, the frame of reference changes to a camera inside the Bel Air. This view exemplifies how, when inside a vehicle, approaching vehicles appear to be travelling at greater speeds.

Students may

- Reflect on prior experiences when passed by a car while stopped at an intersection and compare with being passed while driving.
- Recount personal experiences where they felt like they were moving because of the movement of another object.
- Describe the effect of wind or water current on the motion of a plane or swimmer.
- Consider why airplanes and birds land into the wind.

#### Connection

Teachers may

- Discuss factors affecting air travel (e.g., jet stream, wind direction and strength).
- Demonstrate how birds, gliders and, model aircraft enthusiasts use onshore winds to achieve lift while “slope soaring”.

Students may

- Illustrate an object’s motion from a single frame of reference (e.g., drawing, comic strip, poster board, slide show, video).
- Explain how treadmills or endless pools illustrate the concept of frame of reference.
- Watch Mythbusters *Soccer Ball Shot from a Truck* youtube video and explain the variables at play.
- Participate in a think-pair-share activity to discuss how the speed of an object travelling in different moving media (e.g., air, water) could be calculated.

### Resources and Notes

#### Authorized

*Pearson Physics Level 20* (TR)

- Unit I: Chapter 2 pp. 5-8, 16-20

*Pearson Physics* (SR)

- pp. 91-101

**Outcomes**

*Students will be expected to*

*29.0 identify the frame of reference for a given motion [GCO 3]*

**Focus for Learning****Sample Performance Indicators**

1. A plane is flying at an airspeed of  $50.0 \text{ m/s}$  [N], while there is a headwind of  $15.0 \text{ m/s}$ . What is the velocity of the plane relative to the ground? How long will it take the plane to fly  $1200 \text{ m}$  [N]?
2. A boat travels  $450 \text{ m}$  [N] up a river that flows at  $3.0 \text{ m/s}$  [S], and then returns. The boat has a speed of  $7.0 \text{ m/s}$  with respect to the river. How many seconds will each leg of the trip take? How many seconds will the total trip take?
3. You and a friend go for a ride on your snowmobiles. Your friend has a velocity of  $45.0 \text{ km/h}$  [W], relative to the ground. You observe your friend's velocity to be  $5.0 \text{ km/hr}$  [E], with respect to you. What is your velocity relative to the ground?

---

## Sample Teaching and Assessment Strategies

### Consolidation

Teachers may

- Ask students to solve quantitative 1D relative motion problems on exit cards:
  - A person standing on a trailer walks 2 m [right] while the trailer moves 6 m [right]. What is the displacement of the person relative to the ground? Relative to the trailer?
  - If a trailer moves 6 m [right] and a person on the trailer moves 2 m [left], what is the displacement of the person relative to the ground? Relative to the trailer?
  - Carl walks 3 m/s [right]. Sally walks 4 m/s [right] on a moving sidewalk. What is Carl's displacement relative to Sally after 15 s if the moving sidewalk is traveling at 2 m/s [left]?

Students may

- Investigate, in pairs or small collaborative groups, tossing a ball up in the air while riding on a skateboard. Students may describe the motion of the ball as viewed by the student on the skateboard and by a stationary peer. Capture and share video of the activity from as many frames of reference as can be accessed safely.
- Devise an activity to visually represent the path of a ball being thrown up and down while moving on a skateboard or bicycle.

### Extension

Students may

- Determine the direction a boater would have to travel in order to make landfall directly across a river with a current of  $1.0 \text{ m/s}^2$ .

## Resources and Notes

### Authorized

*Pearson Physics Level 20 (TR)*

- Unit I: Chapter 2 pp. 5-8, 16-20

*Pearson Physics (SR)*

- pp. 91-101

---



---

Section Three:  
Specific Curriculum Outcomes

Unit 2: Dynamics

## Focus

Motion is a fundamental aspect of Physics. Why things move and what causes changes to that motion are the basis for much of this science. Dynamics is the study of those changes and will introduce students to the world of Newton's laws and momentum. This unit blends well with the previous study of kinematics and continues the study of motion in one dimension. Students will be able to tie their real-world experiences to the content, and once again will be able to enhance their understanding through practical, experiential learning. Work in this unit will prepare students for the study of work and energy later in the course.

## Outcomes Framework

**GCO 2 (Skills):** Students will develop the skills required for scientific and technological inquiry, for solving problems, for communicating scientific ideas and results, for working collaboratively, and for making informed decisions.

- 1.0 identify questions to investigate that arise from practical problems and issues
- 2.0 design an experiment identifying and controlling major variables
- 3.0 identify the theoretical basis of an investigation and develop a prediction and a hypothesis that are consistent with the theoretical basis
- 6.0 carry out procedures controlling the major variables and adapting or extending procedures where required
- 8.0 compile and organize data, using appropriate formats and data treatments to facilitate interpretation of the data
- 9.0 use library and electronic research tools to collect information on a given topic
- 10.0 compile and display evidence and information, by hand or computer, in a variety of formats, including diagrams, flow charts, tables, graphs, and scatter plots
- 11.0 identify a line of best fit on a scatter plot and interpolate or extrapolate based on the line of best fit
- 12.0 interpret patterns and trends in data, and infer or calculate linear and nonlinear relationships among variables
- 14.0 compare theoretical and empirical values and account for discrepancies
- 15.0 evaluate the relevance, reliability, and adequacy of data and data collection methods
- 16.0 identify and explain sources of error and uncertainty in measurement and express results in a form that acknowledges the degree of uncertainty
- 18.0 construct and test a prototype of a device or system and troubleshoot problems as they arise
- 19.0 propose alternative solutions to a given practical problem, identify the potential strengths and weaknesses of each, and select one as the basis for a plan
- 20.0 evaluate a personally designed and constructed device on the basis of criteria they have developed themselves
- 22.0 select and use appropriate numeric, symbolic, graphical, and linguistic modes of representation to communicate ideas, plans, and results

**GCO 1 (STSE):** Students will develop an understanding of the nature of science and technology, of the relationships between science and technology, and of the social and environmental contexts of science and technology.

- 30.0 explain how a major scientific milestone revolutionized thinking in the scientific communities
- 34.0 analyze society's influence on scientific and technological endeavours
- 35.0 evaluate the design of a technology and the way it functions on the basis of a variety of criteria that they have identified themselves
- 36.0 analyze and describe examples where technologies were developed based on scientific understanding
- 37.0 describe and evaluate the design of technological solutions and the way they function, using scientific principles

**GCO 3 (Knowledge):** Students will construct knowledge and understandings of concepts in life science, physical science, and Earth and space science, and apply these understandings to interpret, integrate, and extend their knowledge.

- 31.0 use vectors to represent force and acceleration
- 32.0 apply Newton's laws of motion to explain inertia, the relationship between force, mass, and acceleration, and the interaction of forces between two objects
- 33.0 apply quantitatively Newton's laws of motion to impulse and momentum
- 38.0 apply quantitatively the laws of conservation of momentum to one dimensional collisions and explosions

**GCO 4 (Attitudes):** Students will be encouraged to develop attitudes that support the responsible acquisition and application of scientific and technological knowledge to the mutual benefit of self, society, and the environment.

*Students are encouraged to:*

- value the contributions to scientific and technological development made by individuals from many societies and cultural backgrounds
- confidently evaluate evidence and consider alternative perspectives, ideas, and explanations
- use factual information and rational explanations when analyzing and evaluating
- value the processes for drawing conclusions
- show concern for safety and accept the need for rules and regulations
- work collaboratively in planning and carrying out investigations, as well as in generating and evaluating ideas
- show concern for safety and accept the need for rules and regulations

## SCO Continuum

GCO 3 (Knowledge): Students will construct knowledge and understandings of concepts in life science, physical science, and Earth and space science, and apply these understandings to interpret, integrate, and extend their knowledge.

Science 1206	Physics 2204	Physics 3204
<ul style="list-style-type: none"> <li>• describe quantitatively the relationship among motion variables</li> <li>• analyze mathematically the relationship among displacement, velocity, and time</li> <li>• analyze graphically the relationship among displacement, velocity, and time for uniform and non-uniform motion</li> <li>• distinguish between instantaneous and average velocity</li> <li>• describe quantitatively the relationship among velocity, time, and acceleration</li> </ul>	<ul style="list-style-type: none"> <li>• use vectors to represent force and acceleration</li> <li>• apply Newton's laws of motion to explain inertia, the relationship between force, mass, and acceleration, and the interaction of forces between two objects</li> <li>• apply quantitatively Newton's laws of motion to impulse and momentum</li> <li>• apply quantitatively the laws of conservation of momentum to one dimensional collisions and explosions</li> </ul>	<ul style="list-style-type: none"> <li>• use vectors to represent force, velocity, and acceleration</li> <li>• analyze quantitatively the two-dimensional motion in a horizontal plane and a vertical plane</li> <li>• apply Newton's laws of motion to explain inertia, the relationship between force, mass, and acceleration, and the interaction of forces between two objects</li> <li>• apply quantitatively the laws of conservation of momentum to two-dimensional collisions and explosions</li> <li>• describe uniform circular motion, using algebraic vector analysis</li> <li>• explain quantitatively circular motion using Newton's laws</li> </ul>

## Suggested Yearly Plan

September	October	November	December	January	February	March	April	May	June	
<b>Unit 1: Kinematics</b>	<b>Unit 2: Dynamics</b>				<b>Unit 3: Work and Energy</b>			<b>Unit 4: Waves</b>		
<b>Skills Integrated Throughout</b>										

## Developing Laws of Motion

### Outcomes

*Students will be expected to*

30.0 explain how a major scientific milestone revolutionized thinking in the scientific communities [GCO 1]

### Focus for Learning

Use the development of Newton's laws as the context to address this STSE outcome.

Students should

- use research inquiry to briefly summarize the work of Aristotle, Copernicus, Galileo, Kepler, and Newton with respect to force and motion;
- discuss how Newton's work expanded on the work of his predecessors; and
- consider how Newton's laws may have been received by and affected the scientific community of the time.

Student use of research inquiry may constitute evidence to assess skill outcome 9.0. Refer to the *Integrated Skills* unit for elaboration.

Newton's laws revolutionized scientific thinking and formed the basis of classical physics studies for centuries. Briefly introduce Newton's three laws.

- Newton's first law - emphasize that if the net force acting on an object is zero (i.e., forces are balanced) then the object is at rest or moving at a constant velocity.
- Newton's second law - connect to the first law and emphasize that if the net force is not equal to zero (i.e., forces are unbalanced) then the object is accelerating.
- Newton's third law - emphasize that forces only exist in equal and opposite action-reaction pairs. Believing that movement occurs when the reaction force is less than the action force, is a common misconception.

Additionally, briefly discuss that it was later found that some limitations of Newton's laws exist when objects

- approach the speed of light (i.e., relativistic mechanics), and
- are the size of atoms or smaller (i.e., quantum mechanics).

### Attitude

Encourage students to value the contributions to scientific and technological development made by individuals from many societies and cultural backgrounds. [GCO 4]

### Sample Performance Indicator

Use research inquiry to determine the birth and death years of Copernicus, Kepler, Galileo, and Newton and compare findings on a Gantt chart. Describe how the work of Copernicus, Kepler, and Galileo led to the development of Newton's laws.

## *Developing Laws of Motion*

### **Sample Teaching and Assessment Strategies**

#### **Activation**

Teachers may

- Present videos depicting the life and work of Isaac Newton.
- Post chart papers in the room titled Newton's first, second, and third laws and ask students to annotate the chart paper with prior knowledge and examples.

#### **Connection**

Teachers may

- Organize a cooperative jigsaw activity to facilitate students researching and briefly summarizing the works of Aristotle, Copernicus, Galileo, and Kepler.

Students may

- Discuss why we are still learning about Newton's laws some three hundred years after their publication.

#### **Consolidation**

Students may

- Define Newton's three laws and common misconceptions.
- Create a song, poem, or rap about Newton's laws.

### **Resources and Notes**

#### **Authorized**

*Pearson Physics Level 20*  
(Teacher Resource [TR])

- Unit II: Chapter 3 pp. 16-50

*Pearson Physics* (Student Resource [SR])

- pp. 137-193

#### **Suggested**

Resource Links: [www.k12pl.nl.ca/curr/10-12/science/science-courses/physics-2204/resource-links.html](http://www.k12pl.nl.ca/curr/10-12/science/science-courses/physics-2204/resource-links.html)

- History of physics resources (websites)

## Free-Body Diagrams

### Outcomes

*Students will be expected to*

31.0 use vectors to represent force and acceleration  
[GCO 3]

### Focus for Learning

Students should use free-body diagrams to illustrate the forces acting on a mass. The object should be represented as a point or box with arrows illustrating the magnitude (i.e., size) and direction of all forces acting on it. Include the force of friction, normal force, and the force of gravity in free-body diagrams. Students' drawings of free-body diagrams may be used to assess SCO 10.0; displaying information in a variety of formats, including diagrams

Introduce the concept of net force,  $\vec{F}_{\text{net}}$ . Students should use their knowledge of vectors to draw and add force vectors in one dimension.

Students should begin solving problems by finding the net force in just the  $x$ -direction or just the  $y$ -direction (e.g., pushing or pulling on a surface horizontally or moving an object vertically). They should be expected to draw free-body diagrams, create net force statements, and calculate net force by adding vectors, given the forces acting on an object. Note, in this course, net force should always resolve itself into the horizontal and/or vertical plane.

Students should draw free-body diagrams, create net force statements, and calculate net force for objects

- at rest on a horizontal surface,
- accelerating on a horizontal surface (positive and negative acceleration), and
- accelerating toward or away from the ground.

Additionally, students should draw free-body diagrams, create net force statements, and calculate net force for objects that have one force acting at an angle to the horizontal.

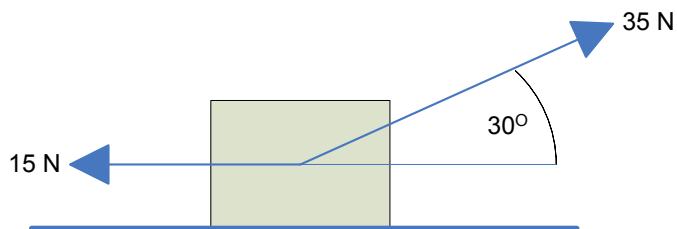

Students are expected to resolve given vectors into horizontal and vertical components. They are not expected to produce the resultant vector from the component vectors.

### Sample Performance Indicators

1. Draw a free-body diagram for a vehicle being towed and create the net force statements.
2. A toboggan is being pulled by three friends. Each friend pulls with a 20 N of force. Draw a free-body diagram and determine the net force if two friends pull forwards and one pulls backwards.



## Free-Body Diagrams

### Sample Teaching and Assessment Strategies

#### Activation

Teachers may

- Engage students in a class tug of war. Discuss the forces they feel and their relative directions. Represent forces in free-body diagrams.

Students may

- Place a coin on an index card over a glass. Then, quickly remove the card so the coin drops in the glass.

#### Connection

Teachers may

- Place an object on a desktop and ask students to describe the forces acting upon it.

Students may

- Illustrate using vector diagrams the change in velocity of an object when an unbalanced force is applied.
- View interactive websites to develop and practice skills for constructing free-body diagrams.

#### Consolidation

Teachers may

- Design an interactive white board activity containing the diagram of a box on a surface with vectors that students can relocate to create free-body diagrams for various situations (e.g., pushed across a frictionless surface).

Students may

- Participate in a small group activity to describe the forces acting on an object, given a free-body diagram. Create net force statements from this diagram and calculate the net force in 1D.
- Draw a free-body diagram from a description of an object, image, or video clip.

#### Extension

Students may

- Draw free-body diagrams for forces acting on an object moving on an inclined plane or in a fluid.

### Resources and Notes

#### Authorized

*Pearson Physics Level 20* (TR)

- Unit II: Chapter 3 pp. 13-15

*Pearson Physics* (SR)

- pp. 129-136

#### Suggested

Resource Links: [www.k12pl.nl.ca/curr/10-12/science/science-courses/physics-2204/resource-links.html](http://www.k12pl.nl.ca/curr/10-12/science/science-courses/physics-2204/resource-links.html)

- Constructing free-body diagrams (websites)

## Newton's Laws

### Outcomes

*Students will be expected to*

- 32.0 apply Newton's laws of motion to explain inertia, the relationship between force, mass, and acceleration, and the interaction of forces between two objects [GCO 3]
- 6.0 carry out procedures controlling the major variables and adapting or extending procedures where required [GCO 2]
- 8.0 compile and organize data, using appropriate formats and data treatments to facilitate interpretation of the data [GCO 2]
- 10.0 compile and display evidence and information, by hand or computer, in a variety of formats, including diagrams, flow charts, tables, graphs, and scatter plots [GCO 2]
- 12.0 *interpret patterns and trends in data, and infer or calculate linear and nonlinear relationships among variables* [GCO 2]

### Focus for Learning

Students should

- state Newton's first law (i.e., law of inertia) and define inertia;
- describe applications of Newton's first law (e.g., seat belts, air bags, pulling a tablecloth out from underneath a place setting without toppling the setting).

Begin treatment of Newton's second law with an investigation using a dynamics cart, pulley system, and timing device. The intent is for students to relate force, mass, and acceleration.



Students should collect data

- with a constant mass on the cart and changing the applied force (weight on the pulley), and
- with a constant applied force and changing the mass on the cart.

Inquiry Lab 3-5 (Pearson Physics, pp.144-145) may be used as a model. Note, the procedure for this lab collects data for a system of constant mass.

In addition to skill outcomes 6.0, 8.0, 10.0, and 12.0, teachers may choose to assess outcomes 3.0, 7.0, 11.0, 17.0, 22.0, and 25.0. Refer to the *Integrated Skills* unit for elaboration of these outcomes.

Students should

- state Newton's second law and describe applications;
- explain how Newton's second law may be used to define the Newton (N) as a unit of force;
- solve problems to calculate the third quantity when given two, or a means of finding two, of net force, mass, and acceleration;
- state Newton's third law and describe applications, and
- draw diagrams identifying action-reaction pairs of forces in various interactions of particles and objects.

Students often incorrectly assume that normal force and the force of gravity are equal. To avoid this misconception, model calculating normal force using net force statements rather than assuming

$$\vec{F}_N = \vec{F}_g.$$

Prior to solving more complex problems involving Newton's laws of motion, the concepts of static and kinetic friction should be addressed. Students should describe static and kinetic friction qualitatively and quantitatively, and provide examples of how they affect motion. Students should come to understand that once an applied force on an object overcomes static friction, a force of kinetic friction is exerted on the object opposing the direction of motion.

*Continued*

## Newton's Laws

### Sample Teaching and Assessment Strategies

#### Activation

Teachers may

- Demonstrate or show a video of the tablecloth trick. Ask students to explain how they think it works.

#### Connection

Teachers may

- Create a question chain or series of questions on index cards to play an "I Have...Who Has" game. Questions should include solving simple, one step problem and definitions of terms.

Students may

- With respect to the Newton's second law directed inquiry investigation
  - Identify the independent, dependent, and controlled variables for each series of trials.
  - Construct appropriate graphs to display data and draw lines of best fit. Compare graphs to those of others and identify discrepancies.
  - Use an online interactive simulation or game to learn about Newton's laws.
- Model changes in normal force. Hold a mass in their hand and experience the normal force. Have a partner change the normal force by lifting up or pushing down on the mass being held. Then switch roles.

#### Consolidation

Students may

- Use Newton's first law to explain why seat belts and air bags are important vehicle safety features.
- With reference to the data from their investigation, describe how acceleration would change if the mass on the cart is doubled or the applied force is tripled.
- Write the relationships among force, mass, and acceleration as proportionality statements.
- Practice solving one- and two-step problems related to net force, mass, and acceleration.
- If an object's maximum force of static friction is 80 N, what happens when 60 N force is applied horizontally on the object? Explain.
- Explain why the coefficient of static friction is always larger than the coefficient of kinetic friction.

### Resources and Notes

#### Authorized

*Pearson Physics Level 20* (TR)

- Unit II: Chapter 3 pp. 16-50

*Pearson Physics* (SR)

- pp. 137-190

Teaching and Learning Strategies

- [www.k12pl.nl.ca/curr/10-12/science/science-courses/physics-2204/teaching-and-learning-strategies.html](http://www.k12pl.nl.ca/curr/10-12/science/science-courses/physics-2204/teaching-and-learning-strategies.html)
  - Static and Kinetic Friction

#### Suggested

Resource Links: [www.k12pl.nl.ca/curr/10-12/science/science-courses/physics-2204/resource-links.html](http://www.k12pl.nl.ca/curr/10-12/science/science-courses/physics-2204/resource-links.html)

- Newton's laws (websites and videos)

#### Notes

The magnifying glass icon is used throughout the unit to indicate investigations.

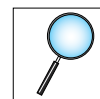

## Newton's Laws

### Outcomes

*Students will be expected to*

32.0 *apply Newton's laws of motion to explain inertia, the relationship between force, mass, and acceleration, and the interaction of forces between two objects*  
[GCO 3]

11.0 identify a line of best fit on a scatter plot and interpolate or extrapolate based on the line of best fit  
[GCO 2]

15.0 evaluate the relevance, reliability, and adequacy of data and data collection methods  
[GCO 2]

16.0 *identify and explain sources of error and uncertainty in measurement and express results in a form that acknowledges the degree of uncertainty*  
[GCO 2]

22.0 select and use appropriate numeric, symbolic, graphical, and linguistic modes of representation to communicate ideas, plans, and results  
[GCO 2]

### Focus for Learning

Students should conduct a guided investigation to determine the coefficients of static and kinetic friction. They should

- personally select classroom objects of differing mass to use in their investigation;
- select a spring scale with an appropriate scale;
- carry out provided procedures, pulling with an ever increasing horizontal force until the mass just starts to move, then continue with constant velocity;
- measure maximum static friction and kinetic friction (use of slow motion video applications on mobile devices may improve measurement accuracy of static friction);
- compile and organize data in an appropriate table;
- adapt or extend procedures to ensure that sufficient, reliable data is collected to determine the coefficients;
- display data in appropriate graphs; and
- draw lines of best fit and calculate slope (i.e., coefficient of friction).

In addition to skill outcomes 11.0, 15.0, 16.0, and 22.0, evidence may be collected to assess SCOs 4.0, 5.0, 6.0, 7.0, 8.0, 10.0, 12.0, 17.0, 21.0, and 25.0. Students may communicate their findings in a lab report. Refer to the *Integrated Skills* unit for elaboration of these outcomes.

Additionally, students should solve problems involving Newton's laws of motion. Problems encountered should include those involving

- pushing or pulling one block, or two blocks positioned next to each other, horizontally (with and without friction),
- two blocks attached by strings moving horizontally (with and without friction),
- gravity and apparent weight (e.g., an elevator),
- lifting one or two blocks (i.e., tension),
- pushing or pulling a block with an applied force at an angle and the block moves horizontally (with and without friction),
- an Atwood machine, and
- two blocks attached by string where one block is on the table and the other hangs off, over a frictionless pulley (with and without friction).

### Attitude

Encourage students to

- use factual information and rational explanations when analyzing and evaluating, and
- value the processes for drawing conclusions. [GCO 4]

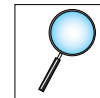

*Continued*

## Newton's Laws

### Sample Teaching and Assessment Strategies

#### Connection

Teachers may

- Model solving multi-step Newton's law problems involving friction. Include
  - writing net force statements in  $x$ - and/or  $y$ -directions;
  - calculating  $\vec{F}_g$ ,  $\vec{F}_N$ , and friction;
  - solving for net force; and
  - solving for acceleration.
- Provide spring scales of varying capacities (e.g., 5N, 10N, 50N). Students should evaluate and select an appropriate spring scale for their investigation.

#### Consolidation

Teachers may

- Assess, for the static and kinetic friction investigation,
  - whether students' calibrate and recalibrate their spring scale;
  - students' sampling technique (e.g., horizontal pull, parallax error, use appropriate significant figures for the scale);
  - whether student procedures included repeated measurements;
  - organization of students collected data;
  - students' graphing technique (e.g., title and labelling, variables on correct axes, appropriate scale, line of best fit); and
  - students' communication of friction coefficients (i.e., accuracy of values, dimensionless).

Students may

- Practice solving problems such as the following:
  - Describe what happens to a student's apparent weight (i.e.,  $\vec{F}_N$ ) on a bathroom scale, when an elevator travels downwards and slows to a stop, and is stopped.

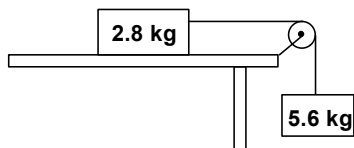

- Determine the tension of the string in the system above. The table-block coefficient of friction is  $\mu_k = 0.23$ .

### Resources and Notes

#### Authorized

*Pearson Physics Level 20* (TR)

- Unit II: Chapter 3 pp. 21-50

*Pearson Physics* (SR)

- pp. 143-190

#### Suggested

Resource Links: [www.k12pl.nl.ca/curr/10-12/science/science-courses/physics-2204/resource-links.html](http://www.k12pl.nl.ca/curr/10-12/science/science-courses/physics-2204/resource-links.html)

- Newton's laws and problems (websites and videos)

*Continued*

## Newton's Laws

### Outcomes

Students will be expected to

32.0 apply Newton's laws of motion to explain inertia, the relationship between force, mass, and acceleration, and the interaction of forces between two objects [GCO 3]

### Focus for Learning

#### Sample Performance Indicators

1. A remote control car, of mass 2.0 kg, is traveling at 4.0 m/s[E] on a frictionless surface. After 8.0 s it moves at 6.0 m/s[W]. Determine the net force acting on the car.
2. With respect to rockets, describe
  - how Newton's first law relates to the launch,
  - how Newton's second law explain why rockets in flight pick up speed and accelerate significantly as fuel burns, and
  - how Newton's third law relates to liftoff.
3. A box of mass 4.5 kg is pushed across a rough surface (force of friction = 7.94 N) for a distance of 2.0 m by a constant force of 10.0 N. If the object reaches a speed of 2.0 m/s by the end of the push, what was its speed at the beginning of the push?
4. A force of 37.0 N is applied to a 2.60 kg cart at an angle of  $30^\circ$ . If  $\mu_k = 0.310$ , at what rate does the cart accelerate?

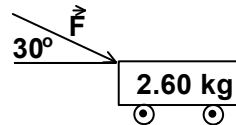

5. Lucy is in an elevator that is accelerating downward at  $1.75 \text{ m/s}^2$ . Her mass is 55.0 kg. What are her weight and apparent weight?
6. A force of 36 N is pulling two carts to the right on a frictionless surface. If Cart 1 has four times the mass of Cart 2, what is the tension in the string connecting the two carts?

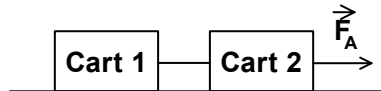

7. Two masses are connected by a massless string over a frictionless pulley as shown. Determine the acceleration of the system of masses.

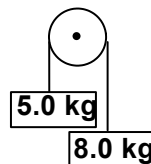

8. Two boxes are in contact on a frictionless surface. An force of 48.0 N is applied to move both boxes horizontally. Determine the force that the 20.0 kg box applies to the 40.0 kg box.

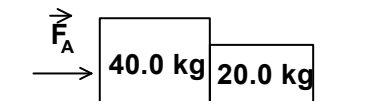

## Newton's Laws

### Sample Teaching and Assessment Strategies

#### Consolidation (continued)

Students may

- Determine the apparent weight of the block in the following diagram.



- Explain using Newton's third law why a skater pushing against the boards at a rink glides off in the opposite direction.
- Explain how inertia may be used to differentiate between two identical looking packages in space, if one is empty and the other contains a heavy object.

#### Extension

Students may

- Solve problems such as the following:
  - Three blocks, attached to each other by a string are pulled along a frictionless horizontal surface by an applied force of 120N. At what rate do the blocks accelerate?

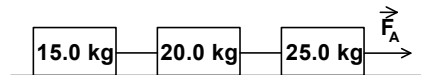

### Resources and Notes

#### Authorized

*Pearson Physics Level 20 (TR)*

- Unit II: Chapter 3 pp. 21-50

*Pearson Physics (SR)*

- pp. 143-190

#### Suggested

Resource Links: [www.k12pl.nl.ca/curr/10-12/science/science-courses/physics-2204/resource-links.html](http://www.k12pl.nl.ca/curr/10-12/science/science-courses/physics-2204/resource-links.html)

- Newton's laws and problems (websites and videos)

## Newton's Laws and Momentum

### Outcomes

*Students will be expected to*

33.0 apply quantitatively  
Newton's laws of motion to  
impulse and momentum  
[GCO 3]

### Focus for Learning

Students should

- define momentum,  $\vec{p}$ ;
- calculate a third quantity when given two of an object's mass, velocity, and momentum;
- define change in momentum as  $\Delta\vec{p} = m\Delta\vec{v}$ ;
- define impulse as  $\vec{F}_{\text{net}}\Delta t$ ;
- calculate impulse from force-time graphs, and
- recognize that impulse equals a change in momentum (i.e., impulse-momentum theorem), and use the theorem to explain related applications and solve quantitative problems.

Starting with  $\vec{F}_{\text{net}} = m\vec{a}$ , teachers should show how  $\vec{F}_{\text{net}}\Delta t = \Delta\vec{p}$  is derived. During the derivation, point out the alternate version of Newton's second law.

$$\vec{F}_{\text{net}} = \frac{\Delta\vec{p}}{\Delta t}$$

Suggested contexts to explore impulse and momentum include sports (e.g., tennis) and car crashes. When an object interacts with a surface or another object, a force is imparted. The magnitude of this force is inversely proportional to the time of contact between the two. This relationship will be explored when addressing the next series of outcomes.

### Sample Performance Indicators

1. The momentum of a 75 g bullet is 36 kg·m/s[N]. What is the velocity of the bullet?
2. With reference to impulse and change in momentum
  - What is the advantage of using safety nets for acrobats?
  - Why are bungee cords better for bungee jumping than rope?
3. Identical balls at rest are given the same release velocity.
  - Compare the applied force if one ball is fired from a slingshot and the other is hit with a bat.
  - Compare the acceleration of each ball.
4. A dog team pulls a 400.0 kg sled that has begun to slide backward. In 4.2 s the velocity of the sled changes from 0.20 m/s[backward] to 1.8 m/s[forward]. Calculate the average net force the dog team exerts on the sled.



## Newton's Laws and Momentum

### Sample Teaching and Assessment Strategies

#### Activation

Teachers may

- Pose questions such as “Would you rather be hit by a slow or fast moving ball?” and “Would you rather be hit with a ping pong or a bowling ball with the same speed?” to help students conceptualize the idea of momentum.
- Facilitate a game of red rover to demonstrate the impulse-momentum theorem.

Students may

- Play catch using balls of differing mass (e.g., ping pong, basketball, medicine ball) and note the force difference when tossing and catching each ball.
- Attempt to move a truck and car placed in neutral. Note and discuss how much effort was required to start the vehicle moving.

#### Connection

Teachers may

- Rearrange the formula for Newton's second law to derive the impulse-momentum theorem equation.

Students may

- Demonstrate how best to catch a basketball thrown at your chest to increase time of contact.
- Explain why they should bend their knees when jumping off the gym stage.
- Describe real-life applications of the impulse-momentum theorem (e.g., goaltenders cradle the puck allowing it to come to rest over a larger distance, resulting in less force; martial artists impart greater force than boxers because they do not follow through).

#### Consolidation

Students may

- Practice solving problems such as the following:
  - A student dropped a 1.5 kg book from a height of 1.75 m. Determine the impulse that the floor exerted on the book when the book hit the floor.
  - If a tennis racket exerts an average force of 55 N and an impulse of 2.0 N·s on a tennis ball, what is the duration of contact?

### Resources and Notes

#### Authorized

*Pearson Physics Level 30* (TR)

- Unit V: Chapter 9 pp. 8-21

*Pearson Physics* (SR)

- pp. 446-467

#### Suggested

Resource Links: [www.k12pl.nl.ca/curr/10-12/science/science-courses/physics-2204/resource-links.html](http://www.k12pl.nl.ca/curr/10-12/science/science-courses/physics-2204/resource-links.html)

- Impulse and momentum resources (websites)

## Newton's Laws and Momentum

### Outcomes

*Students will be expected to*

- 34.0 analyze society's influence on scientific and technological endeavours [GCO 1]
- 35.0 evaluate the design of a technology and the way it functions on the basis of a variety of criteria that they have identified themselves [GCO 1]
- 9.0 use library and electronic research tools to collect information on a given topic [GCO 2]
- 36.0 analyze and describe examples where technologies were developed based on scientific understanding [GCO 1]
- 37.0 describe and evaluate the design of technological solutions and the way they function, using scientific principles [GCO 1]
- 33.0 *apply quantitatively Newton's laws of motion to impulse and momentum* [GCO 3]

### Focus for Learning

SCOs 34.0 and 35.0 highlight an aspect of the relationship among science, technology, society, and the environment; society affects technology. Students should use research inquiry to analyze how automotive technologies are continuously changing to improve safety (e.g., backup cameras, forward collision warning, lane departure assistance) and consider the societal forces that influenced these changes. Additionally, students could analyze improvements to road safety (e.g., divided highways, passing lanes, rumble strips, roundabouts).

Students should, in small collaborative groups, use research inquiry to compare standard and optional safety features on several different makes and models of vehicles. They should identify group criteria and evaluate the vehicles on the basis of these criteria. They should select their preferred vehicle and communicate their choice to classmates, explaining the rationale behind their evaluation. Students should recognize that the criteria they use to select their preferred vehicle demonstrates how society influences technology.

SCOs 36.0 and 37.0 highlight aspects of the relationship between science and technology. Students should analyze and describe specific safety features (e.g., airbags, seat belts, crumple zones, head rests) and relate them to Newton's laws of motion, impulse, and momentum and the impulse-momentum theorem (e.g., crumple zones reduce the applied force in a collision by increasing time). Further, students should describe the design (e.g., parts, materials, specifications) of specific safety features and how they function.

### Attitude

Encourage students to

- show concern for safety and accept the need for rules and regulations, and
- be aware of the direct and indirect consequences of their actions. [GCO4]

## Newton's Laws and Momentum

### Sample Teaching and Assessment Strategies

#### Connection

Students may

- Identify the latest safety features being developed for vehicles.
- Brainstorm criteria that may be used in the evaluation of technologies.
- View crash test safety videos, for old and new vehicles, and new cars and analyze and describe the visible safety features.
- Discuss with students common criteria that could be used to evaluate technological solutions dealing with safety.

#### Consolidation

Students may

- Compile and organize their findings regarding standard and optional safety features for different vehicles in a Pugh chart.
- Discuss or debate
  - Which vehicle safety features are most important?
  - Should safety features be standard on all vehicles or should some features be optional?
  - Is society's regulation of vehicle safety standards and safe driving legislation an infringement on personal freedoms?
- Describe how airbags are an application of the impulse-momentum theorem.

#### Extension

Students may

- Analyze the design and evolution of goalie equipment and explain how it functions in relation to the impulse-momentum theorem.

### Resources and Notes

#### Authorized

*Pearson Physics Level 30* (TR)

- Unit V: Chapter 9 pp. 20-21

*Pearson Physics* (SR)

- pp. 463-465

#### Suggested

Resource Links: [www.k12pl.nl.ca/curr/10-12/science/science-courses/physics-2204/resource-links.html](http://www.k12pl.nl.ca/curr/10-12/science/science-courses/physics-2204/resource-links.html)

[www.k12pl.nl.ca/curr/10-12/science/science-courses/physics-2204/resource-links.html](http://www.k12pl.nl.ca/curr/10-12/science/science-courses/physics-2204/resource-links.html)

- Car safety features resources (websites)

## Newton's Laws and Momentum

### Outcomes

*Students will be expected to*

- 1.0 identify questions to investigate that arise from practical problems and issues  
[GCO 2]
- 18.0 construct and test a prototype of a device or system and troubleshoot problems as they arise  
[GCO 2]
- 19.0 propose alternative solutions to a given practical problem, identify the potential strengths and weaknesses of each, and select one as the basis for a plan  
[GCO 2]
- 20.0 evaluate a personally designed and constructed device on the basis of criteria they have developed themselves  
[GCO 2]

### Focus for Learning

Students should engage in a design challenge to create a structure to protect an egg when dropped from a height. Provide a limited collection of materials (e.g., straws, string, craft sticks, elastic bands, tape, glue, pipe cleaners, assorted fasteners, recycled card board, box board, and paper) for students to use in constructing their structures.

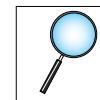

Collaboratively establish design and testing criteria (e.g., drop height, maximum size, no chutes or strings attached, able to easily insert the egg prior to testing).

Students should, in small groups,

- follow an engineering design cycle;
- brainstorm possible design solutions and consider the strengths and weakness of suggested designs;
- select one design to try and devise a construction plan that includes necessary materials and tools;
- construct a prototype, trouble shooting problems as they arise;
- test their prototype (without an egg), making improvements and retesting until a preferred solution is reached;
- submit their final solution for final testing with an egg and evaluation against design criteria; and
- communicate to others the design of their structure, how the design changed as a result of testing, and explain how it applies the impulse-momentum theorem.

In addition to skill outcomes 1.0, 18.0, 19.0, and 20.0, evidence from this design challenge may be collected to assess SCOs 4.0, 21.0, 22.0, 25.0, and 26.0. Refer to the *Integrated Skills* unit for elaboration.

### Attitude

Encourage students to work collaboratively in planning and carrying out investigations, as well as in generating and evaluating ideas.  
[GCO 4]

## *Newton's Laws and Momentum*

### **Sample Teaching and Assessment Strategies**

#### **Connection**

Teachers may

- Present images of engineering design cycles.

Students may

- Pitch their design solution, including sketches, to their group for consideration.
- Devise procedures to test their prototype without an egg.
- Use mobile devices to record slow motion video of prototype testing.
- Use images captured with mobile devices to document changes made to their prototype and the results of testing.

#### **Consolidation**

Students may

- Describe improvements they would make to their design if materials were not limited.
- Evaluate their group processes (e.g., Were all initial suggestions considered equally? Should the prototype have been abandoned in favour of an alternative design?).
- Communicate using oral or written language how the impulse-momentum theorem is applied in their final structure.
- Evaluate the designs of structures constructed by classmates making suggestions for improvement.

### **Resources and Notes**

#### **Authorized**

*Pearson Physics Level 30 (TR)*

- Unit V: Chapter 9 pp. 8-21

*Pearson Physics (SR)*

- pp. 446-467

## Law of Conservation of Momentum

### Outcomes

*Students will be expected to*

38.0 apply quantitatively the laws of conservation of momentum to one dimensional collisions and explosions  
[GCO 3]

### Focus for Learning

Students should

- state the law conservation of momentum (i.e., the total momentum in an isolated system remains constant);
- write an equation applying the law conservation of momentum to a one-dimensional (1D) collision between two objects, in terms of two masses and the two velocities before and after the collision; and
- given any five of the two masses of objects involved in a 1D collision, their velocities before the collision, and their velocities after the collision, calculate the sixth quantity.

Always assume a closed system. Students should recognize that whatever momentum is lost by one object in a collision is gained by the other.

1D conservation of momentum problems encountered should include objects that

- collide and stick together (both moving, one at rest),
- collide and rebound (both moving, one at rest), and
- explode (are pushed apart).

Note, collisions will be readdressed in the *Work and Energy* unit.

### Sample Performance Indicators

1. A 75 kg girl running at 3.0 m/s jumps onto a 5.0 kg sled that was already moving in the same direction as the girl, but at 2.0 m/s. What will be the final velocity of the girl and the sled, assuming that the sled is on level snow and that there is no friction?
2. A 1.49 kg rifle at rest fires a 0.010 kg bullet at a speed of 450 m/s. What will be the recoil velocity of the gun?
3. A 0.020 kg bullet is fired at a speed of 650 m/s through a 5.0 kg stationary block of wood. After exiting the wood, the bullet slows to 450 m/s. What would be the speed of the block of wood immediately after the bullet passed through it?
4. A 1000.0 kg car travels at 25.0 m/s[E] when it collides with a 250.0 kg moose. During the collision both moose and car become entangled, and then continue along the highway at a velocity of 20.0 m/s[E]. What was the speed of the moose before being struck by the car?

## *Law of Conservation of Momentum*

### Sample Teaching and Assessment Strategies

#### Activation

Students may

- Share personal experiences of real-life collisions and explosions.

#### Connection

Teachers may

- Demonstrate using an air track the effect that changing mass and velocity has on a collision with a stationary object.

Students may

- Communicate solutions to law of conservation of momentum problems using vector diagrams.
- Use the online Physics Education Technology (PhET) collision lab simulator to explore the conservation of momentum (to make colliding objects stick together change settings to inelastic).

#### Consolidation

Students may

- Practice solving problems such as the following:
  - Claude and Heather are practicing pairs skating for a competition. Heather (47 kg) is skating with a velocity of 2.2 m/s. Claude (72 kg) is directly behind her skating with a velocity of 3.1 m/s. When he reaches her he holds her waist and they skate together. At the instant he takes hold of her waist, what is their velocity?
  - A 1385 kg canon containing a 58.5 kg canon ball is on wheels. The canon fires the canon ball, giving a velocity of 50.0 m/s[N]. What is the initial velocity of the canon the instant after it fires the canon ball?

#### Extension

Students may

- Describe how conservation of 2D momentum is applied in the sport of curling or pool.

### Resources and Notes

#### Authorized

*Pearson Physics Level 30* (TR)

- Unit V: Chapter 9 pp. 22-30

*Pearson Physics* (SR)

- pp. 468-479

#### Suggested

Resource Links: [www.k12pl.nl.ca/curr/10-12/science/science-courses/physics-2204/resource-links.html](http://www.k12pl.nl.ca/curr/10-12/science/science-courses/physics-2204/resource-links.html)

- PhET interactive collision simulations (website)

## Law of Conservation of Momentum

### Outcomes

Students will be expected to

38.0 apply quantitatively the laws of conservation of momentum to one dimensional collisions and explosions  
[GCO 3]

2.0 design an experiment identifying and controlling major variables  
[GCO 2]

3.0 identify the theoretical basis of an investigation and develop a prediction and a hypothesis that are consistent with the theoretical basis  
[GCO 2]

14.0 compare theoretical and empirical values and account for discrepancies  
[GCO 2]

### Focus for Learning

Students should conduct an open inquiry investigation, colliding two objects and recording relevant data (i.e., initial and final velocities of the objects), to explore the law conservation of momentum. Provide a collection of instruments and materials (e.g., timing devices, measuring devices, dynamics carts, balls) for students to evaluate and use.

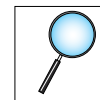

Students should, in small collaborative groups,

- identify the theoretical basis of the investigation (i.e., law conservation of momentum) and develop a hypothesis;
- determine their experimental setup, including the instruments and materials used, and how data will be collected;
- decide whether both objects will be moving or one object will be at rest,
- devise a procedure, controlling major variables, to investigate two collisions, one where the objects stick together and the other where the objects rebound;
- carry out their procedures, controlling major variables, and adapting or extending procedures where required;
- compile and organize their data;
- analyze and interpret data, including a calculation of percent discrepancy; and
- account for discrepancies (e.g., open system).

In addition to skill outcomes 2.0, 3.0, and 14.0, evidence may be collected to assess SCOs 4.0, 6.0, 7.0, 8.0, 15.0, 16.0, 17.0, 21.0, 22.0, 25.0, and 26.0. Students should communicate their findings in a lab report. Refer to the *Integrated Skills* unit for elaboration of these outcomes.

Note, data from this investigation should be kept for later analysis in the *Work and Energy* unit.

### Attitude

Encourage students to

- confidently evaluate evidence and consider alternative perspectives, ideas, and explanations; and
- use factual information and rational explanations when analyzing and evaluating. [GCO 4]



---

*Law of Conservation of Momentum*

---

**Sample Teaching and Assessment Strategies****Resources and Notes****Authorized**

*Pearson Physics Level 30 (TR)*

- Unit V: Chapter 9 pp. 22-30

*Pearson Physics (SR)*

- pp. 468-479



---

Section Three:  
Specific Curriculum Outcomes  
Unit Three: Work and Energy

## Focus

The *Kinematics* unit analyzed how things move and the *Dynamics* unit analyzed why things move. In the *Work and Energy* unit, students will analyze the effects of motion. Work and energy are common terms students have basic knowledge of, however, not necessarily within a physics context. These concepts are some of the easiest to relate to the world around us, allowing opportunities for connections. These real world connections and significant experiential learning will aid students in their understanding.

## Outcomes Framework

**GCO 1 (STSE):** Students will develop an understanding of the nature of science and technology, of the relationships between science and technology, and of the social and environmental contexts of science and technology.

- 37.0 describe and evaluate the design of technological solutions and the way they function, using scientific principles
- 49.0 explain the importance of communicating the results of a scientific or technological endeavour, using appropriate language and conventions
- 52.0 distinguish between scientific questions and technological problems
- 53.0 distinguish between questions that can be answered by science and those that cannot, and between problems that can be solved by technology and those that cannot
- 54.0 analyze natural and technological systems to interpret and explain their structure and dynamics
- 55.0 identify various constraints that result in tradeoffs during the development and improvement of technologies
- 58.0 provide examples of how science and technology are an integral part of their lives and their community
- 61.0 analyze why and how a particular technology was developed and improved over time
- 62.0 analyze examples of Canadian contributions to science and technology

**GCO 2 (Skills):** Students will develop the skills required for scientific and technological inquiry, for solving problems, for communicating scientific ideas and results, for working collaboratively, and for making informed decisions.

- 2.0 design an experiment identifying and controlling major variables
- 4.0 evaluate and select appropriate instruments for collecting evidence and appropriate processes for problem solving, inquiring, and decision making
- 5.0 implement appropriate sampling procedures
- 6.0 carry out procedures controlling the major variables and adapting or extending procedures where required
- 8.0 compile and organize data, using appropriate formats and data treatments to facilitate interpretation of the data
- 9.0 use library and electronic research tools to collect information on a given topic
- 10.0 compile and display evidence and information, by hand or computer, in a variety of formats, including diagrams, flow charts, tables, graphs, and scatter plots
- 11.0 identify a line of best fit on a scatter plot and interpolate or extrapolate based on the line of best fit
- 12.0 interpret patterns and trends in data, and infer or calculate linear and nonlinear relationships among variables
- 15.0 evaluate the relevance, reliability, and adequacy of data and data collection methods
- 17.0 provide a statement that addresses the problem or answers the question investigated in light of the link between data and the conclusion
- 19.0 propose alternative solutions to a given practical problem, identify the potential strengths and weaknesses of each, and select one as the basis for a plan
- 21.0 identify new questions or problems that arise from what was learned
- 22.0 select and use appropriate numeric, symbolic, graphical, and linguistic modes of representation to communicate ideas, plans, and results
- 23.0 identify multiple perspectives that influence a science-related decision or issue
- 24.0 develop, present, and defend a position or course of action, based on findings

**GCO 3 (Knowledge):** Students will construct knowledge and understandings of concepts in life science, physical science, and Earth and space science, and apply these understandings to interpret, integrate, and extend their knowledge.

- 39.0 analyze quantitatively the relationships among force, distance, and work
- 40.0 analyze quantitatively the relationships among work, time, and power
- 41.0 analyze quantitatively the relationships among mass, height, and speed using energy
- 42.0 describe quantitatively mechanical energy as the sum of kinetic and potential energies
- 43.0 analyze quantitatively problems related to kinematics and dynamics using the mechanical energy concept
- 44.0 analyze quantitatively the relationships among force, displacement, and spring constants
- 45.0 explain quantitatively the relationships between displacement, velocity, time, and acceleration for simple harmonic motion
- 46.0 explain quantitatively the relationship between potential and kinetic energies of a mass in simple harmonic motion
- 47.0 determine which laws of conservation of energy or momentum are best used to solve particular real life situations involving elastic and inelastic collisions
- 48.0 analyze common energy transformation situations using the work-energy theorem
- 50.0 analyze quantitatively the relationships among gravitational potential energy, kinetic energy and heat energy using the law of conservation of energy
- 51.0 determine the percent efficiency of energy transformations
- 56.0 describe the products of radioactive decay and the characteristics of alpha, beta, and gamma radiation
- 57.0 describe sources of radioactivity in the natural and constructed environments
- 59.0 apply quantitatively the law of conservation of mass and energy, using Einstein's mass-energy equivalence
- 60.0 compare and contrast qualitatively and quantitatively nuclear fission and fusion

**GCO 4 (Attitudes):** Students will be encouraged to develop attitudes that support the responsible acquisition and application of scientific and technological knowledge to the mutual benefit of self, society, and the environment.

*Students are encouraged to:*

- value the role and contribution of science and technology in our understanding of phenomena that are directly observable and those that are not
- value the processes for drawing conclusions
- confidently evaluate evidence and consider alternative perspectives, ideas, and explanations have a sense of personal and shared responsibility for maintaining a sustainable environment
- project the personal, social, and environmental consequences of proposed action
- appreciate that the applications of science and technology can raise ethical dilemmas

## SCO Continuum

GCO 3 (Knowledge): Students will construct knowledge and understandings of concepts in life science, physical science, and Earth and space science, and apply these understandings to interpret, integrate, and extend their knowledge.

Science 1206	Physics 2204	Physics 3204
<ul style="list-style-type: none"> <li>• describe quantitatively the relationship among motion variables</li> <li>• analyze mathematically the relationship among displacement, velocity, and time</li> <li>• analyze graphically the relationship among displacement, velocity, and time for uniform and non-uniform motion</li> <li>• distinguish between instantaneous and average velocity</li> <li>• describe quantitatively the relationship among velocity, time, and acceleration</li> </ul>	<ul style="list-style-type: none"> <li>• analyze quantitatively the relationships among force, distance, and work</li> <li>• analyze quantitatively the relationships among work, time, and power</li> <li>• analyze the relationships among mass, height, and speed using energy</li> <li>• describe mechanical energy as the sum of kinetic and potential energies</li> <li>• analyze quantitatively problems related to kinematics and dynamics using the mechanical energy concept</li> <li>• analyze the relationships among force, displacement, and spring constants</li> <li>• explain the relationships between time, displacement, velocity, and acceleration for simple harmonic motion</li> <li>• explain quantitatively the relationship between potential and kinetic energies of a mass in simple harmonic motion</li> <li>• determine which laws of conservation of energy or momentum are best used to solve particular real life situations involving elastic and inelastic collisions</li> <li>• use work-energy theorem to analyze common energy transformations</li> <li>• analyze quantitatively the relationships among gravitational potential energy, kinetic energy, and heat energy using the law of conservation of energy</li> <li>• determine the percent efficiency of energy transformations</li> <li>• describe the products of radioactive decay and the characteristics of alpha, beta, and gamma radiation</li> <li>• describe sources of radioactivity in the natural and constructed environments</li> <li>• apply quantitatively the law of conservation of mass and energy, using Einstein's mass-energy equivalence</li> <li>• compare and contrast qualitatively and quantitatively nuclear fission and fusion</li> </ul>	<ul style="list-style-type: none"> <li>• explain quantitatively the Compton effect and the de Broglie hypothesis, using the laws of mechanics, the conservation of momentum, and the nature of light</li> <li>• explain quantitatively the Bohr atomic model as a synthesis of classical and quantum concepts</li> <li>• explain the relationship between the energy levels in Bohr's model, the energy difference between the levels, and the energy of the emitted photons</li> <li>• use the quantum mechanical model to explain natural luminous phenomena</li> </ul>

# Suggested Yearly Plan

September	October	November	December	January	February	March	April	May	June
<b>Unit 1: Kinematics</b>	<b>Unit 2: Dynamics</b>			<b>Unit 3: Work and Energy</b>			<b>Unit 4: Waves</b>		
<b>Skills Integrated Throughout</b>									

DRAFT



DRAFT

## Work

### Outcomes

*Students will be expected to*

39.0 analyze quantitatively the relationships among force, distance, and work [GCO 3]

### Focus for Learning

Students should

- list the conditions under which work is done on an object when a force is applied to it;

$$W = \vec{F} \Delta \vec{d}$$

- define work as a measure of the amount of energy transferred when a force acts parallel to a given displacement; and
- solve problems, calculating the third quantity, when given two of work, displacement, and force, or a means of finding two.

Problems encountered should include examples with a(n)

- force applied at an angle (calculate using  $W = \vec{F} \Delta \vec{d} \cos \theta$ ),
- force applied in the opposite direction to motion, and
- object lifted at a constant velocity.

When an object is lifted and only the mass is known, students should determine the force using  $\vec{F}_g = mg$  and then proceed to calculate work.

In one step,  $W = \vec{F}_g \Delta \vec{d} = mg \Delta \vec{d}$ .

### Sample Performance Indicators

- Calculate the work done by a weight lifter in lifting a 150 kg barbell 1.6 m vertically at a constant velocity.
- A 75 kg boulder rolled off a cliff and fell to the ground below. If the force of gravity did  $6.0 \times 10^4$  J of work on the boulder, how far did it fall?
- A force of 75 N acting at an angle of  $25^\circ$  above the horizontal moves a chair 3.0 m across a level floor. Calculate the work done.
- A 1.1 kg physics book slides to the right on a table at a constant speed. The book encounters a rough patch where the coefficient of kinetic friction is 0.15 and slows down over a distance of 1.5 m. Calculate the work done by friction.
- A locomotive exerts a constant forward force of  $5.4 \times 10^4$  N while pulling a train at a constant velocity of 25 m/s for 1.0 hours. How much work does the locomotive do?

## Work

### Sample Teaching and Assessment Strategies

#### Activation

Teachers may

- Provide examples where work is and is not being done (e.g., lifting a box from the floor to a shelf requires work, holding the same box in position above the floor does not require work).
- Address common misconceptions related to everyday use of the word work and develop a scientific definition of work.

#### Connection

Teachers may

- Using the definition of work, explain why wheelchair ramps are designed on a slight angle and discuss the implications the angle has on the amount of work being done.
- Ask students why long levers are preferred for lifting objects rather than shorter ones?

Students may

- Determine the amount of work done in pushing or lifting an object using a spring scale to determine the force. Calculate and compare the work done for varied distances and angles of applied force.

#### Consolidation

Students may

- Using a sports-related example describe how force, displacement, and work are related.
- Explain whether work is done when a weightlifter holds a barbell above their head and steps forward.
- Explain what a negative value for work represents.

### Resources and Notes

#### Authorized

*Pearson Physics Level 20*  
(Teacher Resource [TR])

- Unit III: Chapter 6 pp. 8-10

*Pearson Physics* (Student Resource [SR])

- pp. 292-294

#### Suggested

Resource Links: [www.k12pl.nl.ca/curr/10-12/science/science-courses/physics-2204/resource-links.html](http://www.k12pl.nl.ca/curr/10-12/science/science-courses/physics-2204/resource-links.html)

- Work resources (websites)

## Power

### Outcomes

*Students will be expected to*

40.0 analyze quantitatively the relationships among work, time, and power  
[GCO 3]

8.0 *compile and organize data, using appropriate formats and data treatments to facilitate interpretation of the data*  
[GCO 2]

12.0 *interpret patterns and trends in data, and infer or calculate linear and nonlinear relationships among variables*  
[GCO 2]

### Focus for Learning

Students may have prior knowledge of the concept of power, such as, horsepower of engines (1 hp = 746 W) and the power generated by hydroelectric dams. This may lead to a misconception that power is energy. Students should define power as the rate at which work is done, measured in Watts, according to the equation

$$P = \frac{W}{\Delta t}, \text{ where } P \text{ is power, } W \text{ is work, and } t \text{ is time.}$$

Students should solve problems, calculating the third quantity, when given two of work, power, and time, or a means of finding two. Include examples solving for power when an object is lifted vertically at a constant speed, using  $P = mgv$ .

Students should recognize that energy equals work. The formula  $E = P\Delta t$  was introduced in Science 9. Students should calculate the cost of buying energy using the equation  $\text{Cost} = E(\text{rate})$ .

They should calculate energy costs from electrical bills per kWh or MJ (1 kWh = 3.6 MJ).

To calculate energy when rates are presented in kWh, students should ensure the unit for power is kW and time is hours, converting if necessary. When rates are presented in MJ, the unit for power is W and time is in seconds. This gives energy in Joules which should be converted to MJ before calculating cost.

Additionally, students should conduct a guided inquiry investigation to determine their power output when running up a flight of stairs.

Students should, in pairs or small groups

- operationally define variables and devise a procedure to measure and record personal mass, the height of the flight of stairs, and the time taken to run up the stairs;
- carry out their procedure, compiling and organizing their data in a table formatted to facilitate power calculations;
- compare their data with classmates; and
- analyze combined data to identify patterns and infer relationships among variables (e.g., time and power) and communicate findings.

In addition to SCOs 8.0, and 12.0, evidence may be collected to assess skill outcomes 5.0, 7.0, 15.0, 16.0, 17.0, and 25.0. Refer to the *Integrated Skills* unit for elaboration.

### Sample Performance Indicator

1. How long would it take a 1.00 kW electric motor on a conveyor belt to do 750 J of work?
2. An automotive hoist motor has a power rating of 420 W and operates for an average of 9 minutes every hour in an 8 hour day. Calculate the yearly cost of operating the hoist motor if the cost of electrical energy is 0.083 \$/kWh.

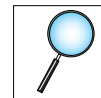

## Power

### Sample Teaching and Assessment Strategies

#### Connection

Teachers may

- Present examples of heat and light bills depicting energy rates and consumption.

Students may

- Find the current energy rate for their community.
- Use the concept of power to explain why a European sports car, which is less massive than an American muscle car, can have an equal finish time in a head to head race.
- Rank the power generated by simple machines doing the same amount of work, given time (e.g., a lever lifts a 50.0 kg mass 1.0 m in 5.0 s, while a pulley lifts the same mass the same distance in 10.0 s).

#### Consolidation

Students may

- Compare how they operationally defined variables in the run up a flight of stairs investigation (e.g., What were the conditions when they started and stopped recording time?).
- Have two group members independently record time in the run up a flight of stairs investigation and average results.
- Calculate the power output of a 55 kg individual when they walk and jog up a flight of 7 stairs. The height of each stair is 17.8 cm and it takes them 4.4 seconds to walk up the stairs and 2.8 seconds to jog up.
- Discuss how the concepts of work, time, and power relate to a 100 m track race. How could a runner achieve more power? Would mass, foot size, stride length, and physical strength be an advantage?
- Explain why the power output of two students of the same mass could be very different

#### Extension

Students may

- Explain how a 250cc two stroke engine produces the same power as a 500cc four stroke engine for motorcycles and snowmobiles.

### Resources and Notes

#### Authorized

*Pearson Physics Level 20 (TR)*

- Unit III: Chapter 6 pp. 25-30

*Pearson Physics (SR)*

- pp. 324-330

#### Suggested

Resource Links: [www.k12pl.nl.ca/curr/10-12/science/science-courses/physics-2204/resource-links.html](http://www.k12pl.nl.ca/curr/10-12/science/science-courses/physics-2204/resource-links.html)

- Power resources (websites)

#### Notes

The magnifying glass icon is used throughout the unit to indicate investigations.

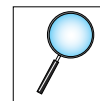

## Forms of Energy

### Outcomes

*Students will be expected to*

41.0 analyze quantitatively the relationships among mass, height, and speed using energy  
[GCO 3]

### Focus for Learning

Students should

- recognize that the work required to lift an object vertically is the same as the gravitational potential energy of the object, relative to a certain reference level;
- define gravitational potential energy in terms of its mass, height, and acceleration due to gravity;
- solve gravitational potential energy problems using the equations  $E = mgh$ , where  $h$  has been substituted for displacement, and  $\Delta E_g = mg\Delta h$ ;
- define an object's kinetic energy in terms of its mass and speed;
- solve kinetic energy problems using the equation  $E_k = \frac{1}{2}mv^2$ ; and
- solve proportionality problems related to kinetic energy (e.g., By what factor will kinetic energy change if the speed is doubled?).

### Sample Performance Indicators

1. An object that has 446 J of gravitation potential energy is 136 m above the ground. What is the object's mass?
2. The gravitational potential energy of an 85.0 kg person changes by 17.5 kJ as she climbs the stairs. If she is initially on the tenth floor and each floor of the building has a height of 3.50 m, what floor has she reached?
3. A car travels at a speed of 20.0 m/s and has a mass of 1200 kg. Determine its kinetic energy.
4. If a rolling ball has 18 J of kinetic energy and is rolling at 3.0 m/s determine it's mass.
5. Object A has half the mass and four times the speed of object B. How does the kinetic energy of object A compare to the kinetic energy of object B?

## Forms of Energy

### Sample Teaching and Assessment Strategies

#### Activation

Teachers may

- Show a video depicting how hydroelectric dams generate power by raising the height of the water relative to the generator. Discuss the water's potential energy and its kinetic energy as it flows through the generator.
- Demonstrate how gravitational potential energy changes by lifting a book to different heights above a desktop and dropping it to produce sound.

#### Connection

Students may

- Analyze qualitatively the relationship among mass, height, and speed using energy. For example,
  - Jared and Clay are climbing stairs. Jared get tired and stops at the fourth floor. Clay continues to the eighth floor. If Jared is twice as heavy as Clay, who has more potential energy?

#### Consolidation

Students may

- Drop an object from differing heights above a bathroom scale and use a mobile device to record the deflection of the value of the scale and compare the values.

#### Extension

Students may

- Explore the concept of terminal velocity and kinetic energy. Include the viewing of *MythBusters Penny Drop* video.

### Resources and Notes

#### Authorized

*Pearson Physics Level 20* (TR)

- Unit III: Chapter 6 pp. 10-13

*Pearson Physics* (SR)

- pp. 295-298, 302-304

#### Suggested

Resource Links: [www.k12pl.nl.ca/curr/10-12/science/science-courses/physics-2204/resource-links.html](http://www.k12pl.nl.ca/curr/10-12/science/science-courses/physics-2204/resource-links.html)

- Gravitational potential energy resources (websites)

## Law of Conservation of Energy

### Outcomes

*Students will be expected to*

42.0 describe quantitatively mechanical energy as the sum of kinetic and potential energies  
[GCO 3]

43.0 analyze quantitatively problems related to kinematics and dynamics using the mechanical energy concept  
[GCO 3]

### Focus for Learning

Students should

- describe mechanical energy as the energy of movement or potential movement;
- identify potential and kinetic energy as the elements of mechanical energy;
- state the law of conservation of energy as it applies to mechanical energy;
- recognize that  $E_m = E_k + E_g$ , in closed systems; and
- solve problems using the law conservation of energy (limit to changes in gravitational potential energy and kinetic energy).

Problem contexts may include roller coasters, hydroelectric dams, objects rising or falling in air, and skateboard ramps.

Kinematics was used to solve problems involving free falling objects in Unit 1. In this unit, students should use the law conservation of energy to solve problems.

Note, in closed systems friction is ignored. Friction produces heat resulting in a mechanical energy loss, but not a total energy loss.

### Sample Performance Indicators

Solve the following

1. A 1.5 kg rock is on top of a 12 m cliff. Determine the speed of the ball as it is about to strike the ground.
2. An 850 kg roller coaster is moving at 22 m/s when 15 m above the ground. If mechanical energy is conserved, how fast is it moving when it is 4.0 m above the ground?



## Law of Conservation of Energy

### Sample Teaching and Assessment Strategies

#### Activation

Teachers may

- Show a video on roller coasters and discuss the energy transformations at different points along the track.

#### Connection

Teachers may

- Discuss how downhill skiing, luge, and skeleton are disciplines that all apply the conversion of  $E_g$  into  $E_k$ .
- Set up a Hot Wheels™ track to demonstrate energy transformations by varying the height of release.

Students may

- Explore energy transformations using the PhET applets *Energy Skate Park Basics* and *Energy Skate Park*.

#### Consolidation

Students may

- Explore roller coaster design and changes in energy from gravitational potential energy to kinetic energies as height and speed change.
- Use the following diagram of a track to calculate the kinetic and potential energy of a 1.0 kg steel ball at points A, B, and C. Assume the ball starts from rest. What is the highest speed the ball would attain? How much force would need to be exerted on the ball to stop it at point C?

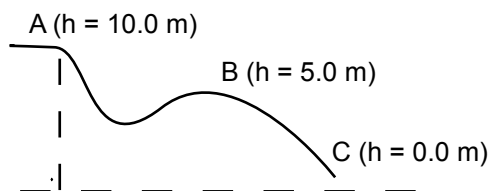

#### Extension

Students may

Design a roller coaster using the PhET *Energy Skate Park* interactive simulator or construct it using Hot Wheels™ or pipe insulation.

### Resources and Notes

#### Authorized

- Pearson Physics Level 20* (TR)
- Unit III: Chapter 6 pp. 15-24
- Pearson Physics* (SR)
- pp. 306-322

#### Suggested

Resource Links: [www.k12pl.nl.ca/curr/10-12/science/science-courses/physics-2204/resource-links.html](http://www.k12pl.nl.ca/curr/10-12/science/science-courses/physics-2204/resource-links.html)

- Law of conservation of energy resources (websites)
- PhET interactive simulations (website)

## Hooke's Law

### Outcomes

*Students will be expected to*

- 44.0 analyze quantitatively the relationships among force, displacement, and spring constants  
[GCO 3]
- 5.0 implement appropriate sampling procedures  
[GCO 2]
- 11.0 identify a line of best fit on a scatter plot and interpolate or extrapolate based on the line of best fit  
[GCO 2]
- 15.0 evaluate the relevance, reliability, and adequacy of data and data collection methods  
[GCO 2]
- 17.0 provide a statement that addresses the problem or answers the question investigated in light of the link between data and the conclusion  
[GCO 2]

### Focus for Learning

Students should perform a guided inquiry investigation to determine the spring constant,  $k$ , of a variety of springs, leading to the development of Hooke's law.

Students should, in small groups,

- operationally define displacement and mass and devise a procedure to measure the stretch of their spring when masses are attached;
- carry out their procedure, controlling major variables, measuring and collecting relevant data;
- compile data in an appropriate table and display it using a force-displacement graph; and
- draw a line of best fit and calculate slope.

Teachers assessment should focus on the appropriateness of student sampling procedures (e.g., choice of appropriate masses, use of repeated measurements, parallax error, consistency in measuring spring displacement). Evidence may also be collected to assess SCOs 6.0, 7.0, 8.0, 10.0, 16.0, 22.0, and 25.0. Refer to the *Integrated Skills* unit for elaboration.

Students should

- define the spring constant,  $k$ ;
- state Hooke's law,  $\vec{F} = -k\vec{x}$  ;
- solve Hooke's law problems, calculating the third value when given two of force, displacement, and  $k$ ;

Address the concept of restoring force.

### Sample Performance Indicators

1. Is the force of the spring greater when the spring is stretch by 1.5 cm or when it is compressed by 1.5 cm? Explain.
2. A spring is stretched 6 cm when a mass of 200 g is hung on it. Calculate the spring constant of the spring.
3. What is the elastic force a spring will exert if it has a spring constant of 175 N/m and is stretched 30.0 cm?



*Hooke's Law***Sample Teaching and Assessment Strategies****Connection**

Teachers may

- Ask students to demonstrate their measurement technique for displacement of a spring.

Students may

- Explore Hooke's law using the PhET interactive *Hooke's Law* simulation.
- Use a mobile device to record their technique when measuring displacement of a spring. Compare their technique to those of other groups.

**Consolidation**

Teachers may

- Present a collection of force-displacement graphs and ask students to identify the stiffest spring.
- Provide several springs with different  $k$  values placed horizontally. Ask students to use spring scales to solve for  $k$ .

Students may

- Reflect on their data and data collection techniques from the Hooke's law investigation and suggest possible changes to their procedure and technique that would improve reliability.
- Calculate the spring constant of a spring scale.
- Conduct an investigation to predict the safe height for a 100 g mass to bungee jump from a ring stand while attached to a chain of elastics (Students determine  $k$  and length for their elastic chain).

**Resources and Notes****Authorized**

*Pearson Physics Level 20* (TR)

- Unit IV: Chapter 7 pp. 13-15

*Pearson Physics* (SR)

- pp. 299, 349-354

Teaching and Learning Strategies

- [www.k12pl.nl.ca/curr/10-12/science/science-courses/physics-2204/teaching-and-learning-strategies.html](http://www.k12pl.nl.ca/curr/10-12/science/science-courses/physics-2204/teaching-and-learning-strategies.html)
  - Discovering Hooke's Law

**Suggested**

Resource Links: [www.k12pl.nl.ca/curr/10-12/science/science-courses/physics-2204/resource-links.html](http://www.k12pl.nl.ca/curr/10-12/science/science-courses/physics-2204/resource-links.html)

- PhET interactive simulations (website)

## Simple Harmonic Motion

### Outcomes

*Students will be expected to*

45.0 explain quantitatively the relationships between displacement, velocity, time, and acceleration for simple harmonic motion  
[GCO 3]

46.0 explain quantitatively the relationship between potential and kinetic energies of a mass in simple harmonic motion  
[GCO 3]

### Focus for Learning

Treatment of SCOs 45.0 and 46.0 should be limited to the oscillation of a spring, with attached mass, on a horizontal frictionless surface.

Students should define simple harmonic motion and recognize that objects obeying Hooke's law undergo simple harmonic motion.

Introduce the concept of acceleration of a moving mass on a spring using Newton's second law. Substituting Newton's second law into Hooke's law creates the equation  $m\vec{a} = -k\vec{x}$ . Solving for acceleration derives the following equation.

$$\vec{a} = \frac{-k\vec{x}}{m}$$

Students should solve problems, calculating for the missing value when given three of acceleration,  $k$ , displacement, and mass.

Introduce elastic potential,  $E_p$ , and connect to students' prior knowledge of potential energy and work. Students should understand that to store energy in a spring work must be done.

Using the force-displacement graph from the Hooke's law investigation, illustrate that the area under the graph is the work done on the spring. Show that Hooke's law can be substituted into the work equation for force, resulting in the following equation.

$$W = \left(\frac{1}{2}k\vec{x}\right)\vec{x}$$

Considering that  $E_p = W$ , this further simplifies to the following.

$$E_p = \frac{1}{2}k\vec{x}^2$$

Revisit the concept of conservation of energy. Students should substitute  $E_p$  for  $E_g$  to solve problems

- calculating potential and kinetic energy for any point in the motion, and
- calculating velocities and displacement from the equilibrium position.

Note, conservation of energy problems were previously limited to gravitational potential energy and kinetic energy. With the introduction of elastic potential energy, problems can be extended to include all three types of energy.

### Sample Performance Indicator

For a spring with a spring constant of 9.0 N/m, calculate the acceleration of an attached 10.0 g mass when the mass is displaced 5.0 cm to the right of its rest position. If the mass is released calculate its velocity

- 2.0 cm to the right of its rest position,
- at rest position, and
- 5.0 cm to the left of its rest position.

## Simple Harmonic Motion

### Sample Teaching and Assessment Strategies

#### Activation

Teachers may

- Present examples of objects exhibiting simple harmonic motion.

#### Connection

Students may

- Calculate the area under the graph for force-displacement graphs of non-constant applied forces.
- Compare the equations for elastic potential and kinetic energies.
- Compare gravitational potential energy with elastic potential energy.

#### Consolidation

Students may

- Solve problems such as
  - A wooden box of mass 6.0 kg slides on a frictionless tabletop with a speed of 3.0 m/s. It is brought to rest by a spring with a spring constant of 1250 N/m. Determine the acceleration of the box when the spring is compressed by 14 cm.
  - A ball of mass 0.50 kg is attached to a horizontal spring. The spring is compressed 0.25 m from its equilibrium position and then released. The ball undergoes simple harmonic motion achieving a maximum speed of 1.5 m/s. Determine the spring constant and calculate the speed of the ball when it is half way to its equilibrium point.
  - Use the diagram below to calculate the  $k$  value of the spring at the bottom of a 10.0 m high track. A 1.0 kg ball, starting from rest, rolls down the track and stops, compressing the spring 2.0 m.

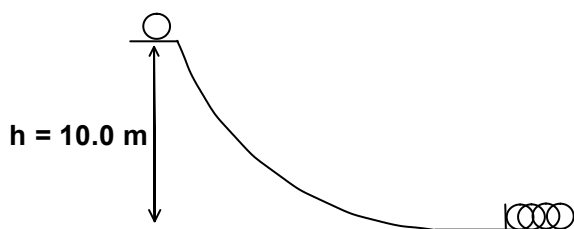

- How fast is the ball rolling just before it strikes the spring?

### Resources and Notes

#### Authorized

*Pearson Physics Level 20* (TR)

- Unit IV: Chapter 7 pp. 20-23

*Pearson Physics* (SR)

- pp. 300-302, 354, 366-372

#### Suggested

Resource Links: [www.k12pl.nl.ca/curr/10-12/science/science-courses/physics-2204/resource-links.html](http://www.k12pl.nl.ca/curr/10-12/science/science-courses/physics-2204/resource-links.html)

- Simple harmonic motion in a spring-mass system resources (websites)

## Elastic Potential Energy

### Outcomes

*Students will be expected to*

47.0 determine which laws of conservation of energy or momentum are best used to solve particular real life situations involving elastic and inelastic collisions [GCO 3]

### Focus for Learning

Students were introduced to the law of conservation of momentum in the *Dynamics* unit. Introduce the concepts of elastic and inelastic collisions using the conservation of kinetic energy. Note, students should not initially be informed that elastic collisions are collision where objects collide and separate and inelastic collisions are those where objects collide and stay together.

Model solving a conservation of momentum problem to determine a final velocity for an elastic and inelastic collision (e.g., Two hockey players collide on the ice. Determine the velocity of one player if they rebound and if they stay together).

Students should solve 1D elastic and inelastic collision problems, determining, using information provided in the problem, which conservation laws, momentum and/or energy, must be applied. Note, calculation of conservation of kinetic energy is required to classify collisions as elastic or inelastic.

In Unit 2, students conducted an investigation, colliding objects to explore the law conservation of momentum (p. 104). Using data from this investigation, students should determine from the initial and final velocities if kinetic energy was conserved through the collision (i.e., Was the collision elastic or inelastic?). At this point, inform students that objects rebound in elastic collisions and stick together in inelastic collision. Note, inaccuracies in the data collected from the initial investigation may result in improper classification of elastic collisions as inelastic.

### Sample Performance Indicator

A 1200 kg Toyota Corolla moving at 25 m/s[E] collides with a 1300 kg Honda Civic moving at 19 m/s[W]. The Corolla rebounds at 27 m/s.

Determine, through calculations, whether the collision is elastic or inelastic.

## Elastic Potential Energy

### Sample Teaching and Assessment Strategies

#### Activation

Teachers may

- Demonstrate a simple collision by having two students stand on skateboards and push away from each other. The velocity of each person could be detected using motion detectors or mobile device applications. Students could then determine whether the collision is elastic or inelastic.

#### Connection

Students may

- Explore the PhET *Collision Lab* simulation.
- Use dynamics carts or an air tracks to investigate various 1D collisions; calculating total kinetic energy to determine if collisions are elastic or inelastic.
- Explain how elastic and inelastic collisions relate to sports (e.g., run-backs in curling).

#### Consolidation

Students may

- For the following data, determine momentum and whether the collision was elastic or inelastic.

m Car 1 (kg)	$V_0$ Car 1 (m/s)	m Car 2 (kg)	$V_0$ Car 2 (m/s)	$V_f$ Car 1 (m/s)	$V_f$ Car 2 (m/s)
1000.0	20.0	1000.0	0.0	10.0	10.0
1000.0	10.0	1000.0	0.0	0.0	10.0
3000.0	30.0	3000.0	15.0	20.0	25.0
2500.0	30.0	1250.0	10.0	15.0	40.0

- Explain how they might predict whether a collision is elastic or inelastic from the information presented in a problem, without performing calculations (e.g., if the final velocities of colliding objects are the same it must be inelastic).

#### Extension

Students may

- Explore how conservation of energy and momentum applies to accident investigation analysis.

### Resources and Notes

#### Authorized

*Pearson Physics Level 30* (TR)

- Unit V: Chapter 9 pp. 30-33

*Pearson Physics* (SR)

- pp. 480-486

#### Suggested

Resource Links: [www.k12pl.nl.ca/curr/10-12/science/science-courses/physics-2204/resource-links.html](http://www.k12pl.nl.ca/curr/10-12/science/science-courses/physics-2204/resource-links.html)

- One-dimensional elastic and inelastic collisions resources (websites)

## Work-Energy Theorem

### Outcomes

*Students will be expected to*

- 48.0 analyze common energy transformation situations using the work-energy theorem [GCO 3]
- 3.0 *identify the theoretical basis of an investigation and develop a prediction and a hypothesis that are consistent with the theoretical basis* [GCO 2]
- 7.0 *use instruments effectively and accurately for collecting data* [GCO 2]
- 8.0 *compile and organize data, using appropriate formats and data treatments to facilitate interpretation of the data* [GCO 2]
- 49.0 explain the importance of communicating the results of a scientific or technological endeavour, using appropriate language and conventions [GCO 1]

### Focus for Learning

When work is done on an object, the kinetic energy of the object changes. This is known as the work-energy theorem,  $W = \Delta E_k$ .

Students should

- state the work-energy theorem as it applies to objects experiencing a force on a horizontal frictionless surface; and
- solve problems involving energy transformations, calculating the value for any variable, given the value of the other variables, or information from which they may be found.

Students should conduct a guided inquiry investigation to confirm the work-energy theorem. The set up may be modelled after Inquiry Lab 3-5 (*Pearson Physics*, pp. 144-145). The mass on the cart may be held constant while the hanging mass varies.

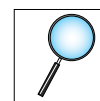

Students should

- collect mass, force, distance, and speed data for the moving cart system when varying hanging masses are attached;
- compile and organize data in a personally constructed tables that facilitates calculation of work and the change in kinetic energy;
- calculate work, using force and distance data, and the change in kinetic energy;
- compare their calculated values for work and the change in kinetic energy to confirm that they are equal;
- find the percent discrepancy, and
- communicate their findings, identifying and explaining sources of error and uncertainty.

Evidence may be collected to assess outcomes 15.0, 16.0, 17.0, 22.0, and 25.0. Refer to the *Integrated Skills* unit for elaboration of skill outcomes.

The importance of communicating the results of their investigation using appropriate language and conventions should be addressed.

### Attitude

Encourage students to value the processes for drawing conclusions. [GCO 4]

### Sample Performance Indicator

1. A car of mass 1000 kg accelerates from 0.0 m/s to 4.0 m/s. How much work is done by the engine?
2. If the car in problem 1 travelled 10.0 m, what was the average force exerted on the car as a result of the actions of the engine?
3. A 50.0 g arrow is pulled back a distance of 80 cm in a bow. When the string is released, it exerts an average force of 60 N on the arrow. With what speed does the arrow leave the bow?



## Work-Energy Theorem

### Sample Teaching and Assessment Strategies

#### Activation

Teachers may

- Show the NRCAN video on efficient driving techniques. Discuss with students the specifics of these techniques and their relationship to the work-energy theorem.

#### Connection

Teachers may

- Elaborate further on the equation for the work-energy theorem to derive the following.

$$F\Delta d\cos\theta = \frac{1}{2}mv_2^2 - \frac{1}{2}mv_1^2$$

Students may

- Calculate the force that decelerates a 65 kg bungee jumper if their speed decreases from 25.0 m/s to 5.0 m/s over a distance of 24 m. Compare this to the same jumper having their deceleration occur over a smaller distance of 12 m.
- Explain why pushing a go-cart with the same constant force over a longer distance will result in a higher speed.
- Use data from their investigation to calculate the area under a force-distance graph and relate it to the calculated values of work done and the change in kinetic energy.

#### Consolidation

Students may

- Calculate how much work is done by a car engine accelerating an 850 kg car from 10.0 m/s to 20.0 m/s. How much more force is applied if the car changes speed over 30.0 m as opposed to 40.0 m? What impact might this have on the gas utilization?

#### Extension

Students may

- Investigate why electric motors, rather than gas motors, are used for acceleration purposes in hybrid vehicles.

### Resources and Notes

#### Authorized

*Pearson Physics Level 20* (TR)

- Unit III: Chapter 6 pp. 14-16

*Pearson Physics* (SR)

- pp. 306-308

#### Suggested

Resource Links: [www.k12pl.nl.ca/curr/10-12/science/science-courses/physics-2204/resource-links.html](http://www.k12pl.nl.ca/curr/10-12/science/science-courses/physics-2204/resource-links.html)

- Work-energy theorem resources (websites)

## Efficiency

### Outcomes

*Students will be expected to*

50.0 analyze quantitatively the relationships among gravitational potential energy, kinetic energy and heat energy using the law of conservation of energy [GCO 3]

51.0 determine the percent efficiency of energy transformations [GCO 3]

3.0 *identify the theoretical basis of an investigation and develop a prediction and a hypothesis that are consistent with the theoretical basis* [GCO 2]

4.0 evaluate and select appropriate instruments for collecting evidence and appropriate processes for problem solving, inquiring, and decision making [GCO 2]

18.0 *construct and test a prototype of a device or system and troubleshoot problems as they arise* [GCO 2]

### Focus for Learning

Students should

- recognize that total mechanical energy is conserved in closed systems;
- recognize that in open systems, energy is transferred outside the system but total energy is still conserved; and
- understand that friction creates heat energy which contributes to the total energy of the system (e.g., when a box slides down an incline the remaining energy is available as kinetic energy at the bottom).

Introduce the concept of energy efficiency. Students should

- calculate percent efficiency for energy transformations using the following formula; and

$$\text{Percent Efficiency} = \left( \frac{E_{\text{out}}}{E_{\text{in}}} \right) \times 100\%$$

- given values for two of the variables above, or a means of finding two, solve for the missing variable.

Students should

- design and construct a roller coaster, using simple materials (e.g., pipe insulation or pool noodle cut vertically, eaves trough, Hot Wheels™ track, paper towel rolls);
- determine the measurements required to calculate total energy of the object at the top and bottom of their roller coaster (i.e., mass of the object, height at top of coaster, speed at bottom of coaster);
- select appropriate instruments and sampling procedures (e.g., motion sensors, slow motion camera, Vernier™);
- devise and carryout a procedure to collect data, including multiple trials;
- calculate energy of the object at the top and bottom of the coaster and percent efficiency of the system;
- communicate their values and provide explanations for the loss of energy;
- suggest changes to improve the reliability and adequacy of data and data collection methods; and
- suggest how they could change their roller coaster design or materials to improve the efficiency of the system.

In addition to SCOs 3.0, 4.0, and 18.0, evidence may be collected to assess skill outcomes 5.0, 6.0, 7.0, 15.0, 16.0, 22.0, 25.0, and 26.0. Refer to the *Integrated Skills* unit for elaboration of skill outcomes.

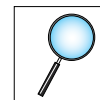

*Continued*

## Efficiency

### Sample Teaching and Assessment Strategies

#### Activation

Teachers may

- Introduce energy transformations in a pendulum using the *PhET Pendulum Lab* simulation. Discuss with students how this supports the law of conservation of energy.

Students may

- List factors that may reduce the efficiency of a machine or mechanical system.

#### Connection

Students may

- Examine braking systems on roller coasters. Discuss how the braking system could effect results from conservation of energy calculations. Note, when a roller coaster comes to a stop, work has to be done against the moving cart and, therefore, friction is provided over a distance, generating heat. In essence, the kinetic energy of the cart is transferred to heat energy.
- Compare the calculated efficiency of their roller coaster using different data collection techniques.

#### Consolidation

Students may

- Design and build their own skate park using the *PhET Energy Skate Park* simulation.
- Suggest changes to the roller coaster designs of others to improve the efficiency of the system.
- Determine the efficiency of ramps using an object of their choice.

#### Extension

Students may

- Improve the design of their roller coaster to increase efficiency.

### Resources and Notes

#### Authorized

*Pearson Physics Level 20* (TR)

- Unit III: Chapter 6 p. 17-25

*Pearson Physics* (SR)

- pp. 314-316, 324

Teaching and Learning Strategies

- [www.k12pl.nl.ca/curr/10-12/science/science-courses/physics-2204/teaching-and-learning-strategies.html](http://www.k12pl.nl.ca/curr/10-12/science/science-courses/physics-2204/teaching-and-learning-strategies.html)
  - Exploring Efficiency

#### Suggested

Resource Links: [www.k12pl.nl.ca/curr/10-12/science/science-courses/physics-2204/resource-links.html](http://www.k12pl.nl.ca/curr/10-12/science/science-courses/physics-2204/resource-links.html)

- PhET interactive simulations (website)
- Roller coaster design (websites and videos)

## Efficiency

### Outcomes

*Students will be expected to*

- 52.0 distinguish between scientific questions and technological problems [GCO 1]
- 21.0 identify new questions or problems that arise from what was learned [GCO 2]
- 50.0 *analyze quantitatively the relationships among gravitational potential energy, kinetic energy and heat energy using the law of conservation of energy* [GCO 3]
- 51.0 *determine the percent efficiency of energy transformations* [GCO 3]

### Focus for Learning

The efficiency of their roller coaster should be used as the context to address SCO 52.0; distinguish between scientific questions and technological problems. This outcome highlights the difference between science and applied science or engineering.

Science starts with a question. Engineering starts with a problem. Students should identify scientific questions to investigate, arising from what was learned about the efficiency of their roller coaster (e.g., How does changing the mass of the roller coaster car affect efficiency? How does changing the height of the initial hill affect the speed of the roller coaster car?), and technological problems to solve (e.g., How can the efficiency of roller coaster car wheels be increased?).

### Sample Performance Indicator

A 2.0 kg cart is pulled up a 3.0 m high ramp with a force of 19 N at a constant speed. If the cart is pulled a distance of 5.0 m up the ramp, calculate the percent efficiency of the ramp.

*Efficiency***Sample Teaching and Assessment Strategies****Resources and Notes****Authorized**

*Pearson Physics Level 20* (TR)

- Unit III: Chapter 6 pp. 17-25

*Pearson Physics* (SR)

- pp. 314-316, 324

Teaching and Learning Strategies

- [www.k12pl.nl.ca/curr/10-12/science/science-courses/physics-2204/teaching-and-learning-strategies.html](http://www.k12pl.nl.ca/curr/10-12/science/science-courses/physics-2204/teaching-and-learning-strategies.html)
  - Exploring Efficiency

**Suggested**

Resource Links: [www.k12pl.nl.ca/curr/10-12/science/science-courses/physics-2204/resource-links.html](http://www.k12pl.nl.ca/curr/10-12/science/science-courses/physics-2204/resource-links.html)

- PhET interactive simulations (website)
- Roller coaster design (websites and videos)

## STSE - Electrical Energy Generation

### Outcomes

*Students will be expected to*

37.0 describe and evaluate the design of technological solutions and the way they function, using scientific principles  
[GCO 1]

9.0 use library and electronic research tools to collect information on a given topic  
[GCO 2]

53.0 distinguish between questions that can be answered by science and those that cannot, and between problems that can be solved by technology and those that cannot  
[GCO 1]

23.0 identify multiple perspectives that influence a science-related decision or issue  
[GCO 2]

54.0 analyze natural and technological systems to interpret and explain their structure and dynamics  
[GCO 1]

### Focus for Learning

This series of STSE and skill outcomes should be addressed as part of a collaborative investigation into different sources of electrical energy, and more specifically, the sanctioning of the Muskrat Falls Hydroelectric Generating Facility to replace the Holyrood Thermal Generating Station to meet future provincial energy needs. This investigation is intended to be completed with 3-4 instructional periods.

Students should

- identify renewable and non-renewable sources of electrical energy (e.g., solar, wind, hydro, geothermal, biomass, fossil fuels [oil, natural gas, coal], nuclear);
- use research inquiry to collect information regarding different electricity generation technologies (e.g., design of the technology, the way the technology functions, positives and negatives of use); and
- describe and evaluate the design and functioning of electricity generation technologies researched.

Use of a cooperative jigsaw strategy to facilitate research is strongly recommended. Technologies researched should include hydro power, thermal power (oil and natural gas), wind, and solar. Other electricity generation technologies may be included (e.g., biomass, geothermal, nuclear, tidal). Nuclear power is addressed separately later in the unit.

Building on their understanding of different electricity generation technologies, students should examine the provincial decision to sanction development of Muskrat Falls to replace the Holyrood generating station and the social and environmental contexts surrounding the decision. They should recognize that there are limits to questions science can answer. Science cannot answer questions that require moral or aesthetic judgement. Additionally, science cannot decide how scientific knowledge should be applied. While science and technology inform the decision making process, humans must decide.

Students should

- collaboratively examine arguments supporting and opposing the decision to close the Holyrood station and develop Muskrat Falls, and
- identify relevant stakeholders and their perspectives.

Students should now analyze the Muskrat Falls project in greater detail and explain the structure and dynamics of the generating facility (i.e., spillway, powerhouse, dams) and transmission projects. Analysis should also include a technical review of energy transformations and efficiency. Students could compare the total energy into the system with the total energy generated and consider possible explanations for the discrepancy.

*Continued*

## STSE - Electrical Energy Generation

### Sample Teaching and Assessment Strategies

#### Activation

Teachers may

- Review with students the concepts of conservation of energy and how potential energy can be converted to kinetic energy. Relate this concept to the inner workings of a variety of power generation techniques.
- Discuss with students the historical context surrounding development and operating of the Churchill Falls Hydroelectric Generating Facility.

#### Connection

Teachers may

- Review with students the provincial Energy Plan: Focusing Our Energy (2007). Discuss elements of the plan that are specific to green-energy solutions. Introduce questions about changing priorities, such as: What seems to be the focus of this plan? How has the view of the province changed since this plan's release?

Students may

- Research green-energy electricity generation and their various efficiencies. Connect this to turbine design and how this has affected the viability of the different power systems.
- Examine the efficiency of other power generation techniques. Compare and contrast these with green-energy in an appropriate format.

#### Consolidation

Teachers may

- Assign perspectives to specific students and facilitate a debate of issues surrounding the development of Muskrat Falls.

### Resources and Notes

#### Suggested

Resource Links: [www.k12pl.nl.ca/curr/10-12/science/science-courses/physics-2204/resource-links.html](http://www.k12pl.nl.ca/curr/10-12/science/science-courses/physics-2204/resource-links.html)

- Muskrat Falls resources (websites)

## STSE - Electrical Energy Generation

### Outcomes

*Students will be expected to*

55.0 identify various constraints that result in tradeoffs during the development and improvement of technologies  
[GCO 1]

19.0 *propose alternative solutions to a given practical problem, identify the potential strengths and weaknesses of each, and select one as the basis for a plan*  
[GCO 2]

24.0 develop, present, and defend a position or course of action, based on findings  
[GCO 2]

### Focus for Learning

The Muskrat Falls Hydroelectric Generating Station may affect society, the environment, and the economy. The effects may be

- expected and favourable,
- expected and unfavourable,
- unexpected and favourable, and
- unexpected and unfavourable.

When developing technologies, the goal is to keep the expected favourable effects greater than expected unfavourable effects. Adopting these technologies involves tradeoffs, accepting risk in exchange for the benefits or giving up one benefit in exchange for another.

Students should identify various constraints influencing the development of Muskrat Falls (i.e., costs, indigenous rights, societal concerns [methylmercury, north spur instability, ice formation, wildlife]) and recognize how these constraints have influenced development of the project.

As a culminating activity, students should, in small collaborative groups, revisit the decision to sanction development of Muskrat Falls and put themselves in the place of the decision makers. They should consider alternative solutions (e.g., wind, solar, natural gas), in addition to the development of Muskrat Falls, identify the potential strengths and weaknesses of each, and select one as the basis for a plan.

Students should

- develop an evidence based plan supporting their preferred position or course of action,
- present their plan in an appropriate format, and
- defend their position or course of action from criticism.

### Attitude

Encourage students to

- confidently evaluate evidence and consider alternative perspectives, ideas, and explanations,
- have a sense of personal and shared responsibility for maintaining a sustainable environment, and
- project the personal, social, and environmental consequences of proposed action. [GCO4]



---

*STSE - Electrical Energy Generation*

---

**Sample Teaching and Assessment Strategies****Resources and Notes****Suggested**

Resource Links: [www.k12pl.nl.ca/curr/10-12/science/science-courses/physics-2204/resource-links.html](http://www.k12pl.nl.ca/curr/10-12/science/science-courses/physics-2204/resource-links.html)

- Muskrat Falls resources (websites)

DRAFT

## Radioactivity

### Outcomes

*Students will be expected to*

56.0 describe the products of radioactive decay and the characteristics of alpha, beta, and gamma radiation [GCO 3]

### Focus for Learning

Review nuclear terms and notation (e.g., proton, neutron, atomic number, atomic mass number). Students should calculate the number of protons, neutrons, and electrons for an atom given the atomic number and atomic mass number.

Introduce isotopes and isotope notation (e.g.,  ${}^{238}_{92}\text{U}$  and uranium-238). Students should

- define isotope;
- define radioactivity and explain the natural process of decay;
- describe the products of alpha decay, beta-negative decay, beta-positive decay, and gamma decay (Note, neutrinos, anti-neutrinos, and electron capture are not expectations of Physics 2204);
- define and describe the characteristics of alpha, beta, and gamma radiation; and
- create radioactive decay equations, identify reaction type, and balance equations with one reactant or product missing.

Students should be able to identify  $\alpha$ ,  $\beta^-$ ,  $\beta^+$ ,  $\gamma$  decay products and the daughter elements when given the parent element and decay type.

### Sample Performance Indicator

Solve the following.

1. What daughter particle is formed when  ${}^{238}_{92}\text{U}$  emits an  $\alpha$  particle?
2. Write the reaction equation for  $\beta^-$  decay of  ${}^{90}_{38}\text{Sr}$
3. Find the missing particle or nucleus for the following.

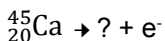

## Radioactivity

### Sample Teaching and Assessment Strategies

#### Activation

Students may

- Identify sources, examples, and uses of radiation, based on prior knowledge.

#### Connection

Teachers may

- Present videos describing radioactive decay and the characteristics of alpha, beta, and gamma radiation.
- Facilitate a matching activity where students match parent elements cards with corresponding daughter element cards. The type of decay may be indicated on either the parent or daughter cards.

Students may

- Explain the difference between uranium-238 and uranium-235.

#### Consolidation

Students may

- Californium-254 undergoes a decay series to become curium-250. Complete the following and identify the decay type.

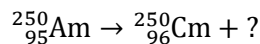
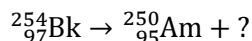
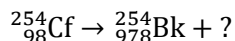
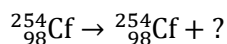

- Write reactions for the following
  - $\alpha$  decay of  ${}_{88}^{226}\text{Ra}$ ,
  - $\beta^+$  decay of  ${}_{29}^{64}\text{Cu}$ , and
  - $\gamma$  decay of argon-38.
- Find the missing particle or nucleus for the following

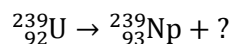
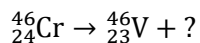

#### Extension

Students may

- Research neutrinos and anti-neutrinos and their importance to chemical equations for radioactive decay.

### Resources and Notes

#### Authorized

*Pearson Physics Level 30* (TR)

- Unit VIII: Chapter 16 pp. 7-15

*Pearson Physics* (SR)

- pp. 790-791, 799-806

#### Suggested

Resource Links: [www.k12pl.nl.ca/curr/10-12/science/science-courses/physics-2204/resource-links.html](http://www.k12pl.nl.ca/curr/10-12/science/science-courses/physics-2204/resource-links.html)

- PhET interactive simulations (website)

## Radioactivity

### Outcomes

*Students will be expected to*

57.0 describe sources of radioactivity in the natural and constructed environments [GCO 3]

58.0 provide examples of how science and technology are an integral part of their lives and their community [GCO 1]

12.0 *interpret patterns and trends in data, and infer or calculate linear and nonlinear relationships among variables* [GCO 2]

### Focus for Learning

Students should identify and describe natural sources of radiation (e.g., cosmic rays, radon gas production from ground, radioisotopes in the ground [uranium, thorium]) and artificial sources of radiation (e.g., nuclear medicine, nuclear waste).

Treatment should address applications of radiation and include

- diagnostic nuclear medicine;
- radiotherapy;
- radioactive dating (e.g., carbon-14, uranium-238); and
- industrial applications (e.g., americium-241 use in smoke detectors).

Additionally, students should

- define half-life;
- interpret graphs showing radioactive decay over time (*Pearson Physics*, pp. 813, 815) and determine half-life from the graph;
- solve problems, using given information, to determine half-life, time over which the decay has occurred, initial amount of radioactive material, and the amount remaining (Note, limit to half-life multiples [i.e., no logs or exponential functions]).

### Attitude

Students will be encouraged to show a continuing and more informed curiosity and interest in science and science-related issues

### Sample Performance Indicators

1. The half-life of U-235 is  $7 \times 10^8$  years. If you have a rock sample containing minerals having 1 unit of  $^{235}\text{U}$  and 3 units of  $^{207}\text{Pb}$ , how old is the rock sample?
2. Determine the half-life from the decay of the radioactive element represented in the graph below.

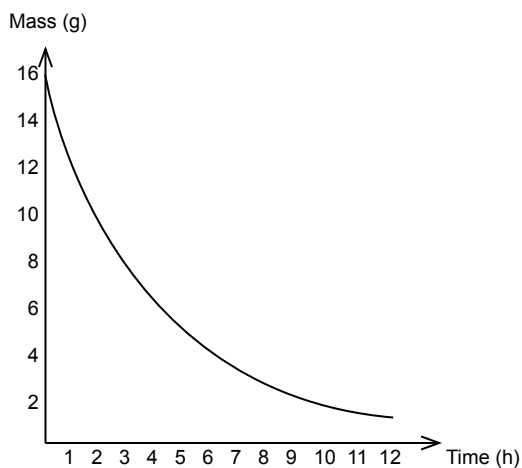

## Radioactivity

### Sample Teaching and Assessment Strategies

#### Connection

Teachers may

- Discuss examples of natural and artificial radiation exposure in our everyday lives (e.g., microwave radiation, radon gas in basements, scanners, solar radiation, X-rays).

Students may

- Investigate how archaeologists use carbon dating to determine the age of artifacts.
- Determine additional sources of radiation in their everyday lives and classify them as constructed or natural.
- Test, if possible, for radiation exposure in their own homes (e.g., microwave radiation, radon gas).
- Investigate how isotopes and nuclear decay are used in diagnostic imaging.

#### Consolidation

Students may

- Solve problems
  - A 10.0 g sample of radioactive tracer iodine-123 is stored on a hospital shelf. Its half-life is 12 hours. How much radioactive material is left after 5.0 days?
  - After 32.0 days of decay, 3.13 g of iodine-131 remains. If the half-life is 8 days. What was the initial amount of iodine-131?
- Research what normal background radiation levels are on average. Determine the background radiation levels for their region and hypothesize why levels are similar to or different from the average.

#### Extension

Students may

- Investigate how to make a homemade radiation detector (i.e., Geiger counter).

### Resources and Notes

#### Authorized

*Pearson Physics Level 30* (TR)

- Unit VIII: Chapter 16 pp. 17-21

*Pearson Physics* (SR)

- pp. 812-817

#### Suggested

Resource Links: [www.k12pl.nl.ca/curr/10-12/science/science-courses/physics-2204/resource-links.html](http://www.k12pl.nl.ca/curr/10-12/science/science-courses/physics-2204/resource-links.html)

- Radioactivity applications (websites)
- Half-life resources (websites)

## Mass-Energy Equivalence

### Outcomes

*Students will be expected to*

59.0 apply quantitatively the law of conservation of mass and energy, using Einstein's mass-energy equivalence [GCO 3]

### Focus for Learning

In Science 1206, students investigated chemical reactions where mass is conserved. In Physics 2204, introduce nuclear reactions where mass is not conserved; illustrating the need for Einstein's mass-energy equivalence.

Revisit the law of conservation of energy and the law of conservation of mass (Science 1206) to introduce Einstein's mass-energy equivalence  $E = mc^2$ .

Students should

- define mass difference;
- determine mass difference for a nuclear reaction; and
- use mass difference to calculate the energy released in a nuclear reaction (i.e., solve for a missing variable, in the  $E = mc^2$  equation given the other two. Note,  $c$  is a constant and is always positive).

Treatment should not include calculations using atomic mass units or MeV.

### Attitude

Students will be encouraged to value the role and contribution of science and technology in our understanding of phenomena that are directly observable and those that are not. [GCO 4]

### Sample Performance Indicators

1. In a nuclear reaction, the mass of the reactants is  $2.38 \times 10^{-18}$  kg and the mass of the products is  $2.35 \times 10^{-18}$  kg. Determine the energy released from this reaction.
2. Calculate the mass difference in a nuclear process that releases  $5.1 \times 10^{-13}$  J.
3. Write the equation for  $\alpha$  decay of radium-226 and calculate the energy released in the reaction using the following information.

	Mass (kg)
${}^{226}_{88}\text{Ra}$	$3.752 \times 10^{-25}$
${}^{222}_{86}\text{Rn}$	$3.685 \times 10^{-25}$
${}^4_2\text{He}$	$6.644 \times 10^{-27}$

## Mass-Energy Equivalence

### Sample Teaching and Assessment Strategies

#### Activation

Students may

- Revisit the law of conservation of mass by balancing chemical reactions (Science 1206).
- Review energy transformations in a closed system (p. 120).
- Review how the mass of a nucleus changes during a nuclear decay reaction.

#### Connection

Students may

- Newfoundland and Labrador requires  $2.52 \times 10^{13}$  J of electrical energy annually to meet our current needs. What change in mass of fissionable material would be required to supply this energy? (Assume no energy loss)

#### Consolidation

Students may

- Calculate the energy released in an alpha decay reaction for uranium-236 (Note, uranium-236 decays to thorium-232 and helium-4).
- The total luminosity (energy radiated per second) of the Sun is about  $3.85 \times 10^{26}$  J/s. How much mass of the Sun is being converted to energy every second?

### Resources and Notes

#### Authorized

*Pearson Physics Level 30* (TR)

- Unit VIII: Chapter 16 pp. 7-9

*Pearson Physics* (SR)

- pp. 793-796

## Fission and Fusion

### Outcomes

*Students will be expected to*

60.0 compare and contrast qualitatively and quantitatively nuclear fission and fusion [GCO 3]

61.0 analyze why and how a particular technology was developed and improved over time [GCO 1]

62.0 analyze examples of Canadian contributions to science and technology [GCO 1]

### Focus for Learning

Students should

- define fission and fusion,
- classify given reactions as fission or fusion,
- compare and contrast the processes with respect to products as compared reactants and the energy released, and
- calculate energy released by fission and fusion reactions (See p. 140).

To address SCO 62.0, students should

- briefly research the history of nuclear power and its use in generating electricity,
- identify how the technology has improved over time, and
- consider the pros and cons of nuclear power generation.

Students should recognize CANDU nuclear reactors as an example of a Canadian contribution to science and technology. They should

- describe how nuclear reactors generate electricity; and
- analyze the parts and safety systems (i.e., moderator dump, cadmium control rods, moderator "poison") of a CANDU nuclear reactor.

### Attitude

Students should be encouraged to appreciate that the applications of science and technology can raise ethical dilemmas.

### Sample Performance Indicators

1. Create a quick reference guide to distinguish nuclear fusion reactions from nuclear fission reactions.
2. Classify the following nuclear reaction. Calculate the mass difference and the energy released.

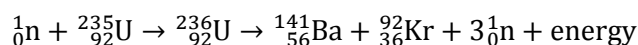

Particle	Mass (kg)
neutron	$1.6749 \times 10^{-27}$
${}_{92}^{235}\text{U}$	$3.9017 \times 10^{-25}$
${}_{56}^{141}\text{Ba}$	$2.3392 \times 10^{-25}$
${}_{36}^{92}\text{Kr}$	$1.5259 \times 10^{-25}$



## Fission and Fusion

### Sample Teaching and Assessment Strategies

#### Activation

Teachers may

- Present videos describing how fusion powers stars.

#### Connection

Teachers may

- Present videos describing nuclear fission and fusion.

Students may

- Compare and contrast figures 16.17 and 16.18 (*Pearson Physics*, pp. 819, 821).
- Compare the benefits of electrical generation from nuclear power with other forms of electrical generation investigated earlier in the unit (e.g., hydro, solar, wind).
- Investigate past nuclear disasters (e.g., Chernobyl, Fukushima) including their causes and effects.

#### Consolidation

Students may

- Identify the following reaction as fission or fusion and calculate the energy released.

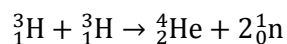

$${}^3_1\text{H} = 5.007 \times 10^{-27}\text{kg} \quad {}^4_2\text{He} = 6.644 \times 10^{-27}\text{kg} \quad {}^1_0\text{n} = 1.6749 \times 10^{-27}\text{kg}$$

- Find the mass difference in a nuclear reaction if the energy released is  $2.98 \times 10^{-11}$  J.

#### Extension

Students may

- The mass of the Sun is estimated to be  $1.989 \times 10^{30}$  kg. Given that 71% of the sun is made up of hydrogen, determine how much more helium can be produced.

### Resources and Notes

#### Authorized

*Pearson Physics Level 30* (TR)

- Unit VIII: Chapter 16 pp. 22-25

*Pearson Physics* (SR)

- pp. 818-824

---

DRAFT

---

Section Three:  
Specific Curriculum Outcomes  
Unit Four - Waves

## Focus

The study of waves is not new to students. Wave characteristics and properties of light were investigated in Science 8. *Waves and Dynamics* builds on students' prior learning and their personal experiences with waves in nature. Waves applications related to sound and electromagnetic radiation are integral to our society and personal lives.

Students will investigate the dynamics of waves and explore these phenomena through the use of concrete materials.

## Outcomes Framework

**GCO 1 (STSE):** Students will develop an understanding of the nature of science and technology, of the relationships between science and technology, and of the social and environmental contexts of science and technology.

- 34.0 analyze society's influence on scientific and technological endeavours
- 35.0 evaluate the design of a technology and the way it functions on the basis of a variety of criteria that they have identified themselves
- 37.0 describe and evaluate the design of technological solutions and the way they function, using scientific principles
- 67.0 analyze the knowledge and skills acquired in their study of science to identify areas of further study related to science and technology
- 68.0 analyze from a variety of perspectives the risks and benefits to society and the environment of applying scientific knowledge or introducing a particular technology

**GCO 2 (Skills):** Students will develop the skills required for scientific and technological inquiry, for solving problems, for communicating scientific ideas and results, for working collaboratively, and for making informed decisions.

- 2.0 design an experiment identifying and controlling major variables
- 6.0 carry out procedures controlling the major variables and adapting or extending procedures where required
- 8.0 compile and organize data, using appropriate formats and data treatments to facilitate interpretation of the data
- 12.0 interpret patterns and trends in data, and infer or calculate linear and nonlinear relationships among variables
- 15.0 evaluate the relevance, reliability, and adequacy of data and data collection methods
- 26.0 evaluate individual and group processes used in planning, problem solving and decision making, and completing a task

**GCO 3 (Knowledge):** Students will construct knowledge and understandings of concepts in life science, physical science, and Earth and space science, and apply these understandings to interpret, integrate, and extend their knowledge.

63.0 describe the characteristics of longitudinal and transverse waves  
64.0 apply the wave equation to explain and predict the behaviour of waves  
65.0 describe how sound and electromagnetic radiation, as forms of energy, are produced and transmitted  
66.0 compare and describe the properties of electromagnetic radiation and sound  
69.0 explain qualitatively and quantitatively the phenomena of wave interference, reflection, diffraction  
70.0 explain qualitatively and quantitatively the Doppler-Fizeau effect  
71.0 explain qualitatively and quantitatively the phenomena of wave refraction  
72.0 apply the laws of reflection and the laws of refraction to predict wave behaviour

**GCO 4 (Attitudes):** Students will be encouraged to develop attitudes that support the responsible acquisition and application of scientific and technological knowledge to the mutual benefit of self, society, and the environment.

*Students are encouraged to:*

- value the role and contribution of science and technology in our understanding of phenomena that are directly observable and those that are not
- appreciate that the applications of science and technology can raise ethical dilemmas encouraged to want to take action for maintaining a sustainable environment
- show a continuing and more informed curiosity and interest in science and science-related issues, and
- consider further studies and careers in science- and technology-related fields
- value processes for drawing conclusions
- work collaboratively in planning and carrying out investigations, as well as in generating and evaluating ideas.

## SCO Continuum

GCO 3 (Knowledge): Students will construct knowledge and understandings of concepts in life science, physical science, and Earth and space science, and apply these understandings to interpret, integrate, and extend their knowledge.

Science 1206	Physics 2204	Physics 3204
<ul style="list-style-type: none"> <li>• describe quantitatively the relationship among motion variables</li> <li>• analyze mathematically the relationship among displacement, velocity, and time</li> <li>• analyze graphically the relationship among displacement, velocity, and time for uniform and non-uniform motion</li> <li>• distinguish between instantaneous and average velocity</li> <li>• describe quantitatively the relationship among velocity, time, and acceleration</li> </ul>	<ul style="list-style-type: none"> <li>• describe the characteristics of longitudinal and transverse waves</li> <li>• apply the wave equation to explain and predict the behaviour of waves</li> <li>• describe how sound and electromagnetic radiation, as forms of energy, are produced and transmitted</li> <li>• compare and describe the properties of electromagnetic radiation and sound</li> <li>• explain qualitatively and quantitatively the phenomena of wave interference, reflection, diffraction</li> <li>• explain qualitatively and quantitatively the Doppler-Fizeau effect</li> <li>• explain qualitatively and quantitatively the phenomena of wave refraction</li> <li>• apply the laws of reflection and the laws of refraction to predict wave behaviour</li> </ul>	<ul style="list-style-type: none"> <li>• describe how the quantum energy concept explains black-body radiation and the photoelectric effect</li> <li>• explain qualitatively and quantitatively the photoelectric effect</li> <li>• summarize the evidence for the wave and particle models of light</li> <li>• explain quantitatively the Compton effect and the de Broglie hypothesis, using the laws of mechanics, the conservation of momentum, and the nature of light</li> <li>• explain quantitatively the Bohr atomic model as a synthesis of classical and quantum concepts</li> <li>• explain the relationship between the energy levels in Bohr's model, the energy difference between the levels, and the energy of the emitted photons</li> <li>• use the quantum mechanical model to explain natural luminous phenomena</li> </ul>

## Suggested Unit Plan

September	October	November	December	January	February	March	April	May	June	
<b>Unit 1: Kinematics</b>		<b>Unit 2: Dynamics</b>			<b>Unit 3: Work and Energy</b>			<b>Unit 4: Waves</b>		
<b>Skills Integrated Throughout</b>										

DRAFT

## Longitudinal and Transverse Waves

### Outcomes

Students will be expected to

63.0 describe the characteristics of longitudinal and transverse waves [GCO 3]

### Focus for Learning

In Science 8, students were introduced to features of a wave and qualitatively described frequency. In Physics 2204, students should identify wave characteristics including amplitude, crest, trough, wavelength, compression, and rarefaction.

Students should differentiate between longitudinal and transverse waves. They should recognize that for

- transverse waves, the displacement or oscillations in the medium is perpendicular to the direction of energy propagation (e.g., electromagnetic waves, waves on strings); and

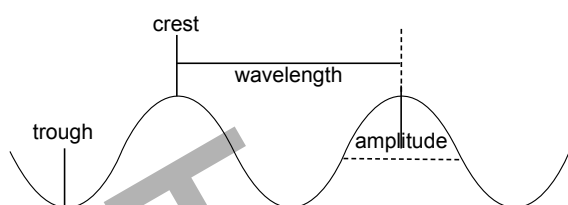

- longitudinal waves, the particle movement is parallel to the direction of energy propagation (e.g., sound waves).

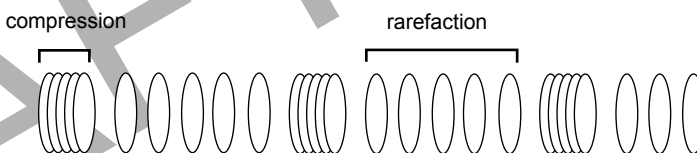

Students should

- describe the frequency ( $f$ ) and period ( $T$ ) of a wave,
- calculate frequency (Hz) and period, and
- understand how period is the inverse of the frequency of a wave.

$$f = \frac{\# \text{ cycles}}{\text{time}} \quad T = \frac{\text{time}}{\# \text{ cycles}} \quad f = \frac{1}{T}$$

### Sample Performance Indicators

- A bicycle wheel does 12 revolutions in 2.5 s. What is the frequency of the wheel?
- A disc is revolving with a frequency of 120 Hz. What is the period of the revolution?
- A wave takes 3.2 s to complete 8 cycles. What is the period and frequency of the wave?
- If the time between compressions of a longitudinal wave is 0.020 s, what is the frequency?



## Longitudinal and Transverse Waves

### Sample Teaching and Assessment Strategies

#### Activation

Teachers may

- Demonstrate frequency and period using a pendulum.

Students may

- List real life events that occur in cyclic patterns and discuss them in terms of their frequency.
- Label a diagram of a traverse wave with previously known terminology from Science 8.

#### Connection

Students may

- Use the PhET simulation *Wave on a String* to explore waves and pulses.
- Use a spring to create transverse waves and take measurements to calculate period and frequency.
- Calculate wavelength and amplitude from diagrams of longitudinal and transverse waves.
- Investigate how a pulse moves through a spring (*Pearson Physics*, Inquiry Lab 8-4, p. 403).
- Investigate the speed, amplitude, and length of pulses (*Pearson Physics*, Inquiry Lab 8-5, p. 405).

#### Consolidation

Students may

- Sketch a sound wave and light or water wave and outline the difference between the wave types.
- For a wave of 60.0 Hz, calculate the period.

### Resources and Notes

#### Authorized

*Pearson Physics Level 20*  
(Teacher Resource [TR])

- Unit IV: Chapter 8 pp. 8-18, 21-22

*Pearson Physics* (Student Resource [SR])

- pp. 392-406, 411-413

Teaching and Learning Strategies

- [www.k12pl.nl.ca/curr/10-12/science/science-courses/physics-2204/teaching-and-learning-strategies.html](http://www.k12pl.nl.ca/curr/10-12/science/science-courses/physics-2204/teaching-and-learning-strategies.html)
  - Wave Lab

#### Suggested

Resource Links: [www.k12pl.nl.ca/curr/10-12/science/science-courses/physics-2204/resource-links.html](http://www.k12pl.nl.ca/curr/10-12/science/science-courses/physics-2204/resource-links.html)

- longitudinal and transverse wave resources (websites)
- PhET interactive simulations (website)

## Universal Wave Equation

### Outcomes

*Students will be expected to*

64.0 apply the wave equation to explain and predict the behaviour of waves [GCO 3]

### Focus for Learning

For the purposes of this course, students should only work with waves that travel with uniform motion. Thus, the speed of the wave would be expressed as

$$v = \frac{\Delta d}{\Delta t},$$

where  $d$  is the distance the wave travelled in time  $t$ .

Show how the universal wave equation is derived.

$$v = \frac{\Delta d}{\Delta t} \quad \Delta d = \lambda, \Delta t = T$$

$$v = \frac{\lambda}{T} \quad f = \frac{1}{T}$$

$$v = f\lambda$$

Students should apply the universal wave equation to calculate speed, frequency, and wavelength, when given two of these values or a means of finding two.

### Attitude

Encourage students to value the role and contribution of science and technology in our understanding of phenomena that are directly observable and those that are not. [GCO 4]

### Sample Performance Indicators

Solve the following:

- Two radio stations broadcast at different frequencies. The AM station broadcasts at 640 kHz, while the FM station broadcasts at 96.9 MHz. Compare the wavelengths of each if the waves travel at  $3.00 \times 10^8$  m/s.
- The distance between 7 wave crests on a lake was estimated to be 12.0 metres in length. If it takes 10.0 seconds for these 7 wave crests to pass by your boat, calculate the wave speed.
- What is the frequency of a wave travelling at 5.3 m/s if the wavelength is 2.5 m?

## Universal Wave Equation

### Sample Teaching and Assessment Strategies

#### Connection

Teachers may

- Revisit demonstrations of longitudinal and transverse waves in springs and make connections between distance and wavelength, time and period, and then discuss how the speed of waves could be determined.

Students may

- Use a spring to create a wave and calculate its speed using measured wavelength and frequency or period.
- Describe how the speed, amplitude, and wavelength of an ocean wave change as it approaches the shoreline.
- Describe how the frequency, wavelength, and speed of tidal waves compare to typical ocean waves.

#### Consolidation

Teachers may

- Distribute cards with frequency or period, and wavelength data for a given wave. Ask students to calculate the speed of their wave and sequence themselves in ascending order.

Students may

- View video of waves and take measurements to calculate wave speed.
- Propagate and capture images of waves with a ruler (or similar measurement tool) visible in the image. Use the images to take measurements and calculate wave speed.

### Resources and Notes

#### Authorized

*Pearson Physics Level 20* (TR)

- Unit IV: Chapter 8 pp. 18-19

*Pearson Physics* (SR)

- pp. 408-409

Teaching and Learning Strategies

- [www.k12pl.nl.ca/curr/10-12/science/science-courses/physics-2204/teaching-and-learning-strategies.html](http://www.k12pl.nl.ca/curr/10-12/science/science-courses/physics-2204/teaching-and-learning-strategies.html)
  - Wave Lab

## Sound and Electromagnetic Radiation

### Outcomes

*Students will be expected to*

65.0 describe how sound and electromagnetic radiation, as forms of energy, are produced and transmitted [GCO 3]

66.0 compare and describe the properties of electromagnetic radiation and sound [GCO 3]

2.0 *design an experiment identifying and controlling major variables* [GCO 2]

15.0 *evaluate the relevance, reliability, and adequacy of data and data collection methods* [GCO 2]

26.0 evaluate individual and group processes used in planning, problem solving and decision making, and completing a task [GCO 2]

### Focus for Learning

In Science 8, students

- identified and described properties of visible light (i.e., rectilinear propagation, reflection, refraction, dispersion, does not require a medium to transmit, interacts differently with transparent, translucent, and opaque materials);
- described different types of electromagnetic radiation (i.e., infrared, ultraviolet, X-rays, microwaves, radio waves); and
- compared the properties of visible light and other types of electromagnetic radiation.

Review the electromagnetic properties addressed in Science 8 and identify the speed of light.

Students should compare and describe sound and electromagnetic radiation, with respect to

- how they are produced;
- type of wave;
- transmission (i.e., medium dependence or independence); and
- speed (i.e., temperature dependence or independence, variability when moving from a less to a more dense medium [and vice versa]).

Students should design an open inquiry investigation to calculate the speed of sound using echoes. They should

- evaluate and select appropriate materials to collect the data required for calculation of the speed of sound;
- devise and carry out a procedure, considering the sound source and medium, controlling major variables;
- compile and organize distance, time, and temperature data to facilitate interpretation;
- use their experimental data to calculate the speed of sound;
- compare their experimental value with an accepted value dependent on temperature (using the formula below), calculate percent discrepancy, and account for discrepancies, and

$$v = 322 \text{ m/s} + 0.6 \left( \frac{\text{m/s}}{^{\circ}\text{C}} \right) T$$

- communicate their procedure and calculated value for the speed of sound to others.

Students should reflect on their experimental design and data collection to suggest improvements. They should also evaluate their group processes used in designing and carrying out the investigation.

In addition to SCOs 2.0, 15.0, and 26.0, evidence may be collected to assess outcomes 3.0, 4.0, 5.0, 6.0, 7.0, 8.0, 10.0, 14.0, 15.0, 16.0, 17.0, 21.0, 22.0, and 25.0. Students may communicate their findings in a lab report. Refer to the *Integrated Skills* unit for elaboration of these skill outcomes.

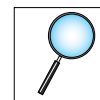

*Continued*

## Sound and Electromagnetic Radiation

### Sample Teaching and Assessment Strategies

#### Activation

Teachers may

- Discuss how the type of gas affects the pitch of sound we hear.
- Review electromagnetic properties addressed in Science 8.
- Ask students if they have ever counted the time between a flash of lightning and the subsequent clap of thunder. This phenomena could help explain how the speed of sound is slower than light.
- Present videos explain the creation and transmission of sound and the role of the medium.

Students may

- Create concept maps for light and sound. As the unit progresses, maps can be revised and expanded to incorporate new learning.

#### Connection

Students may

- Use a PhET simulation to visualize sound waves created by different sound sources and hear the effect of listener position on sound.
- Explain how counting seconds between a flash of lightning and hearing thunder can be used to determine how far away the lightning strike was. They may consider whether the light seen instantaneously, if there is a source of error not considered in this calculation, and what would happen if light and sound travelled at the same speed.

#### Consolidation

Students may

- A band student tunes an instrument at home prior to performing at a cold outdoor venue. Would there be a difference in the actual frequencies heard? Explain.
- You are at an outdoor concert on a 30.0°C day. The stage is 320 m away from you. A friend in Vancouver is listening to the same concert via satellite. Assuming no delay in transmission, the satellite signal travels a total distance of 30 000 km to reach your friend. If the satellite transmission travels at  $3.00 \times 10^8$  m/s, who will hear the sound from the stage first?

#### Extension

Students may

- Investigate how interference patterns can be used to tune guitars.

### Resources and Notes

#### Authorized

- Pearson Physics Level 20* (TR)
- Unit IV: Chapter 8 pp. 14-20
- Pearson Physics* (SR)
- pp. 401-408

#### Suggested

Resource Links: [www.k12pl.nl.ca/curr/10-12/science/science-courses/physics-2204/resource-links.html](http://www.k12pl.nl.ca/curr/10-12/science/science-courses/physics-2204/resource-links.html)

- Sound waves (videos and websites)
- PhET interactive simulations (website)

#### Notes

The magnifying glass icon is used throughout the unit to indicate investigations.

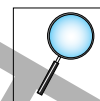

## Sound and Electromagnetic Radiation

### Outcomes

Students will be expected to

65.0 describe how sound and electromagnetic radiation, as forms of energy, are produced and transmitted [GCO 3]

66.0 compare and describe the properties of electromagnetic radiation and sound [GCO 3]

2.0 design an experiment identifying and controlling major variables [GCO 2]

15.0 evaluate the relevance, reliability, and adequacy of data and data collection methods [GCO 2]

26.0 evaluate individual and group processes used in planning, problem solving and decision making, and completing a task [GCO 2]

### Focus for Learning

#### Attitude

Encourage students to

- value processes for drawing conclusions
- work collaboratively in planning and carrying out investigations, as well as in generating and evaluating ideas. [GCO 4]

#### Sample Performance Indicators

1. Create a chart to compare sound and electromagnetic radiation.
2. An explosion occurring at sea creates a shock wave that travels through the water, reaching the shore in 5.0 seconds. The speed of sound in water is 1450 m/s. If the speed of sound in the air is 340 m/s, how long will it take to hear the explosion?
3. Explain why inhaling helium ( $v_s=927$  m/s) makes your voice sound higher pitched. What prediction can be made if someone inhales sulphur hexafluoride ( $v_s=120$  m/s)?
4. Create sketches to illustrate how light and sound waves would change as they travel from air into another denser medium such as glass.

---

*Sound and Electromagnetic Radiation*

---

**Sample Teaching and Assessment Strategies****Resources and Notes****Authorized**

*Pearson Physics Level 20* (TR)

- Unit IV: Chapter 8 pp. 14-20

*Pearson Physics* (SR)

- pp. 401-408

**Suggested**

Resource Links: [www.k12pl.nl.ca/curr/10-12/science/science-courses/physics-2204/resource-links.html](http://www.k12pl.nl.ca/curr/10-12/science/science-courses/physics-2204/resource-links.html)

- Sound waves (videos and websites)
- PhET interactive simulations (website)

## Applications of Sound Waves

### Outcomes

*Students will be expected to*

67.0 analyze the knowledge and skills acquired in their study of science to identify areas of further study related to science and technology [GCO 1]

68.0 analyze from a variety of perspectives the risks and benefits to society and the environment of applying scientific knowledge or introducing a particular technology [GCO 1]

### Focus for Learning

Students should recognize that the study of sound and electromagnetic radiation can lead to varied careers as acquired knowledge and skills are applied in different areas.

To illustrate, introduce ultrasonic waves as sound waves with a frequency above 20 kHz. Students should conduct an Internet search to identify applications of ultrasound technology and potential career opportunities in these areas.

Application of ultrasound technologies in some areas (e.g., medicine, oil and gas exploration) have both favourable and unfavourable effects. Use of these technologies involves tradeoffs (e.g., accepting an unfavourable effect to gain favourable effects).

Students should

- collaboratively select a controversial application of ultrasound technology;
- identify multiple perspectives related to the issue;
- analyze the favourable and unfavourable effects of using the technology; and
- develop and defend a position on the issue, based on their analysis.

Note, this outcome could be deferred until later in the unit and address applications of light as well as sound.

### Attitude

Encourage students to

- appreciate that the applications of science and technology can raise ethical dilemmas encouraged to want to take action for maintaining a sustainable environment,
- show a continuing and more informed curiosity and interest in science and science-related issues, and
- consider further studies and careers in science- and technology-related fields. [GCO 4].



## *Applications of Sound Waves*

### **Sample Teaching and Assessment Strategies**

#### **Activation**

Students may

- Explore the origin of the term ultrasonic.

#### **Connection**

Students may

- Identify a career of personal interest in an ultrasonic field. Research the education and training required for this career and future prospects. Communicate results to classmates.
- Search the explorecuriosity website to identify applications of ultrasound technologies and related careers.
- Review research into the effects of ultrasonic radiation on human health.
- Describe how bats, or other organisms, use echolocation for navigation.

#### **Consolidation**

Students may

- Debate the use of ultrasound technology for
  - offshore oil and gas exploration, or
  - non-diagnostic fetal imaging.

### **Resources and Notes**

#### **Authorized**

*Pearson Physics Level 20* (TR)

- Unit IV: Chapter 8 pp. 34-35

*Pearson Physics* (SR)

- pp. 433-434

#### **Suggested**

Resource Links: [www.k12pl.nl.ca/curr/10-12/science/science-courses/physics-2204/resource-links.html](http://www.k12pl.nl.ca/curr/10-12/science/science-courses/physics-2204/resource-links.html)

- Ultrasound applications (websites)

*Wave Interference, Reflection, and Diffraction*

**Outcomes**

*Students will be expected to*

69.0 explain qualitatively and quantitatively the phenomena of wave interference, reflection, and diffraction [GCO 3]

69.1 explain qualitatively and quantitatively the phenomena of wave interference and reflection of sound

**Focus for Learning**

Students should

- recognize that the amplitude of interfering waves is predicted by the principle of superposition;
- distinguish between constructive and destructive interference;
- identify two waves that are in phase and two waves that are out of phase, given a diagram; and
- sketch two transverse waves that will superimpose to produce a
  - larger amplitude,
  - smaller amplitude, and
  - no amplitude.

Note, limit treatment of the principle of superposition to diagrams of simple transverse wave pulses.

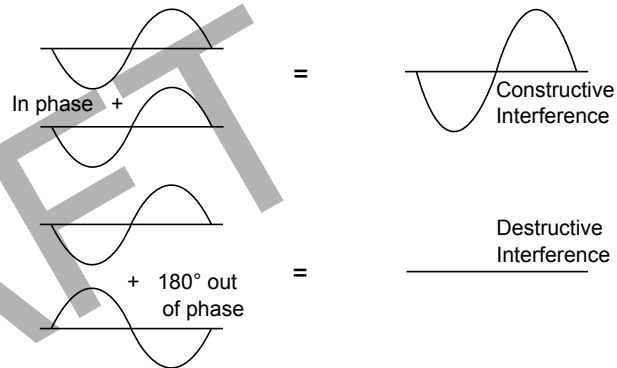

Relate the principle of superposition to the reflection of a wave fixed at one end (See Figure 8.16, *Pearson Physics*, p. 404). Demonstrate fixed end reflection using a slinky or string.

Introduce standing wave patterns on a string. Students should

- identify nodes and antinodes; and
- calculate wavelength, frequency, length, and speed of the standing wave.

Note, standing wave patterns should be referred to by harmonic number (no overtones).

*Third Harmonic: Standing Wave on a String*

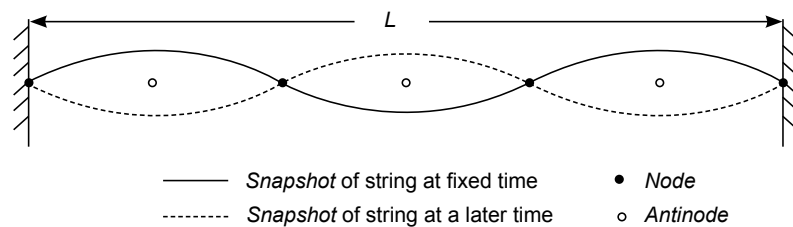

*Continued*

## Wave Interference, Reflection, and Diffraction

### Sample Teaching and Assessment Strategies

#### Activation

Students may

- Conduct part 1 of Inquiry Lab 8-6 (*Pearson Physics*, p. 414) to introduce the concepts of interference and superposition.
- Blow across the mouth of a bottle to demonstrate resonance.

#### Connection

Teachers may

- Demonstrate how the speed of sound can be measured using a water filled tube closed at one end (Inquiry Lab 8-7, *Pearson Physics*, p. 421). Ask students to compare the experimental value obtained from this demonstration with their calculated value for the investigation on page 156.
- Create cards depicting transverse waves in different phases and resultant interference. Distribute cards to students. Ask students to match cards such that two interfering waves produce the resultant interference pattern.
- Distribute two cards to students depicting transverse waves in different phases and ask them to use the principle of superposition to sketch the resultant wave.
- Demonstrate various examples of resonance (e.g., wine glass, Barton's pendulum, resonance boxes).
- Present videos depicting resonance patterns in sand caused by sound waves vibrating a steel plate.

Students may

- Use interactive online simulators to visualize transverse waves undergoing constructive and destructive interference.
- Create standing waves using springs and calculate wavelength, frequency, length, and speed of the standing wave.
- Draw standing waves for different harmonics and identify patterns in the number of nodes and antinodes.
- Explore standing wave patterns in musical instruments.
- Explore why sound speakers at a concert can induce nausea.

### Resources and Notes

#### Authorized

*Pearson Physics Level 20* (TR)

- Unit IV: Chapter 8 pp. 21-30

*Pearson Physics* (SR)

- pp. 411-424

Teaching and Learning Strategies

- [www.k12pl.nl.ca/curr/10-12/science/science-courses/physics-2204/teaching-and-learning-strategies.html](http://www.k12pl.nl.ca/curr/10-12/science/science-courses/physics-2204/teaching-and-learning-strategies.html)
  - Wave Lab

#### Suggested

Resource Links: [www.k12pl.nl.ca/curr/10-12/science/science-courses/physics-2204/resource-links.html](http://www.k12pl.nl.ca/curr/10-12/science/science-courses/physics-2204/resource-links.html)

- Constructive and destructive wave interference simulators (websites)
- Resonance resources (websites and videos)

## Wave Interference, Reflection, and Diffraction

### Outcomes

Students will be expected to

69.0 explain qualitatively and quantitatively the phenomena of wave interference, reflection, and diffraction [GCO 3]

69.1 explain qualitatively and quantitatively the phenomena of wave interference and reflection of sound

### Focus for Learning

Students should relate the number of antinodes in standing waves to wavelength.

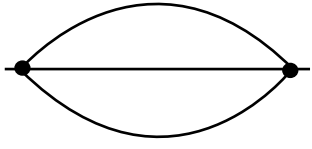
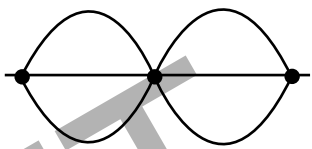
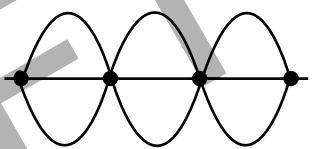
Harmonic	Pattern	# of Antinodes	Length-Wavelength Relationship
1 <sup>st</sup>		1	$L = 1/2\lambda$
2 <sup>nd</sup>		2	$L = 2/2\lambda$
3 <sup>rd</sup>		3	$L = 3/2\lambda$

Discuss resonance in closed end air columns (e.g., blowing across the top of a pop bottle, wind instruments). Students should

- define resonance and natural resonant frequencies,
- draw the first three resonant patterns for a closed-end tube,
- recognize resonance in a closed-end tube as a standing wave,
- recognize that resonance is dependent on the length of a closed-end tube (See Figure 8.33, *Pearson Physics*, p. 419), and
- calculate the length, wavelength, frequency, and speed for these patterns.

### Sample Performance Indicators

1. A string 6.0 meters long is vibrating in the third harmonic. It vibrates up and down with 45 cycles in 10.0 seconds. Determine the frequency, period, wavelength, and speed for this wave.
2. A  $3.10 \times 10^2$  Hz tuning fork is held over the mouth of an air column open at one end. If the speed of sound is 352 m/s, calculate the length of the air column which produces the second resonant sound.
3. A 840 Hz tuning fork is held over an air column that is open at one end. If the temperature is 15°C, calculate the length of the air column that produces the second resonant sound.

## Wave Interference, Reflection, and Diffraction

### Sample Teaching and Assessment Strategies

#### Consolidation

Students may

- Conduct part 2 of Inquiry Lab 8-6 (*Pearson Physics*, pp. 414-415) to determine what causes standing waves and observe the effects of frequency and wavelength on standing wave patterns.
- Practice solving problems such as
  - A string is vibrating in the 3rd harmonic at a frequency of 360 Hz and a wavelength of 48 cm. What are the wavelength and frequency of the second harmonic, and the speed of each wave?
  - When a tuning fork is held over an adjustable tube open at one end, the distance between the 1st and 2nd resonant lengths is measured to be 0.12 m. Draw the standing wave pattern for the 1st and 2nd resonant length. What is the wavelength of the sound causing the resonance?

### Resources and Notes

#### Authorized

*Pearson Physics Level 20* (TR)

- Unit IV: Chapter 8 pp. 21-30

*Pearson Physics* (SR)

- pp. 411-424

Teaching and Learning Strategies

- [www.k12pl.nl.ca/curr/10-12/science/science-courses/physics-2204/teaching-and-learning-strategies.html](http://www.k12pl.nl.ca/curr/10-12/science/science-courses/physics-2204/teaching-and-learning-strategies.html)
  - Wave Lab

#### Suggested

Resource Links: [www.k12pl.nl.ca/curr/10-12/science/science-courses/physics-2204/resource-links.html](http://www.k12pl.nl.ca/curr/10-12/science/science-courses/physics-2204/resource-links.html)

- Constructive and destructive wave interference simulators (websites)
- Resonance resources (websites and videos)

## Wave Interference, Reflection, and Diffraction

### Outcomes

Students will be expected to

69.0 explain qualitatively and quantitatively the phenomena of wave interference, reflection, and diffraction  
[GCO 3]

69.2 explain qualitatively and quantitatively the phenomena of wave interference and diffraction of light

### Focus for Learning

Introduce the wave model of light and note the importance of the double slit experiment as evidence supporting this model.

Extend the phenomenon of wave interference to light. Demonstrate interference patterns produced for double slit experiments.

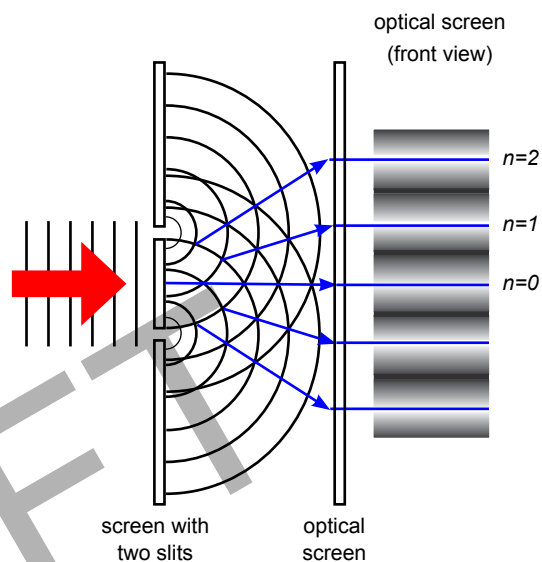

Students should solve problems using the formula for double slit maximas;

$$\sin\theta = \frac{n\lambda}{d}$$

where

$n$  = order number (e.g., 0, 1, 2, 3);

$\lambda$  = wavelength of the light source (m);

$d$  = width between two slits/slit separation (m); and

$\theta$  = angle of diffraction (See Figure 13.78, *Pearson Physics*, p. 690).

Limit calculations to maximas. Calculations should only involve variables associated with the above equation. Trigonometry calculations involving distances (i.e., from central maxima) and screen distances are not an expectation of Physics 2204.

### Sample Performance Indicators

1. Calculate the angle of the second order maxima for light of wavelength 550 nm if it illuminates a double slit of width  $2.5 \times 10^{-6}$  m.
2. The third order maxima in a double slit experiment occurs at an angle of  $15^\circ$ . Calculate the wavelength of light used if the slit separation is  $2.2 \times 10^{-6}$  m.
3. The first order maxima in a double slit experiment occurs at an angle of  $10.0^\circ$ . Calculate the slit separation if a 625 nm light source is used.

## Wave Interference, Reflection, and Diffraction

### Sample Teaching and Assessment Strategies

#### Activation

Teachers may

- Relate the diffraction of a sound wave through an opening to the diffraction of a light wave.

#### Connection

Teachers may

- Use the PhET simulation *Wave Interference* to demonstrate the pattern of bright and dark spots produced. Alternatively, use a laser pointer and double slit.
- Trace wavefronts from a double slit demonstration to explain how constructive and destructive interference produce the pattern of bright and dark spots.
- Discuss the conditions required to create the diffraction pattern.

Students may

- Explore how the use of different coloured light (e.g., red, green, blue) affects the diffraction pattern produced by a double slit.
- Use the PhET simulation *Wave Interference* to explore the effect of different variables (e.g., slit width, distance to screen, location of double slit with respect to the light source, colour of light) on the diffraction pattern produced.

#### Consolidation

Students may

- Practice solving problems for double slit maximas.

### Resources and Notes

#### Authorized

*Pearson Physics Level 30* (TR)

- Unit VII: Chapter 13  
pp. 36-39

*Pearson Physics* (SR)

- pp. 685-690

#### Suggested

Resource Links: [www.k12pl.nl.ca/curr/10-12/science/science-courses/physics-2204/resource-links.html](http://www.k12pl.nl.ca/curr/10-12/science/science-courses/physics-2204/resource-links.html)

- PhET interactive simulations (website)

## Doppler-Fizeau Effect

### Outcomes

*Students will be expected to*

70.0 explain qualitatively and quantitatively the Doppler-Fizeau effect  
[GCO 3]

### Focus for Learning

Students should

- define and describe Doppler effect,
- explain Doppler effect qualitatively for both sound and light, and
- solve Doppler-related problems quantitatively (limit treatment for light to a radar beam fired at a moving target from a stationary car) using the following formulas.

$$f = \frac{f_0 v_s}{v_s \pm v_0} \qquad v_r = \left( \frac{\Delta f}{2f_1} \right) c$$

Note, for the purposes of Physics 2204, the term Doppler effect can be used in reference to both sound and light.

### Sample Performance Indicators

1. With the speed of sound at 325 m/s, an ultrasonic wave is detected with a frequency of  $3.00 \times 10^4$  Hz from a stationary source. If the wave source recedes at 15.0 m/s, what is the frequency detected by a stationary listener?
2. A radar gun is used to clock the speed of a hockey puck at 108 km/h. The radar gun emits wave of frequency 2.50 GHz. What was the change in frequency detected by the radar gun?
3. Discuss changes in frequencies heard from vehicles when a spectator is at a race track watching vehicles approach then pass by them, and move on.



## Doppler-Fizeau Effect

### Sample Teaching and Assessment Strategies

#### Connection

Teachers may

- Present videos demonstrating and explaining the Doppler effect.

Students may

- Describe how the pitch of a siren changes as it moves toward and then away from you.

#### Consolidation

Teachers may

- Provide actual and observed frequencies of a moving source. Ask students if the source is moving towards or away from the observer.

Students may

- Describe how police radar measures the velocity of a moving car.
- Practice solving Doppler-related problems quantitatively (*Pearson Physics*, p. 432).

#### Extension

Students may

- Research and describe the phenomena of blue shift and red shift in astronomy.

### Resources and Notes

#### Authorized

*Pearson Physics Level 20* (TR)

- Unit IV: Chapter 8 pp. 32-34

*Pearson Physics* (SR)

- pp. 429-432

#### Suggested

Resource Links: [www.k12pl.nl.ca/curr/10-12/science/science-courses/physics-2204/resource-links.html](http://www.k12pl.nl.ca/curr/10-12/science/science-courses/physics-2204/resource-links.html)

- PhET interactive simulations (website)

## Wave Refraction and Snell's Law

### Outcomes

*Students will be expected to*

- 71.0 explain qualitatively and quantitatively the phenomena of wave refraction [GCO 3]
- 72.0 apply the laws of reflection and the laws of refraction to predict wave behaviour [GCO 3]
- 6.0 *carry out procedures controlling the major variables and adapting or extending procedures where required* [GCO 2]
- 8.0 *compile and organize data, using appropriate formats and data treatments to facilitate interpretation of the data* [GCO 2]
- 12.0 *interpret patterns and trends in data, and infer or calculate linear and nonlinear relationships among variables* [GCO 2]

### Focus for Learning

In Science 8, students demonstrated the laws of reflection and described images created in plane mirrors. They also investigated refraction qualitatively.

Students should

- use terminology related to the laws of reflection and refraction (See Figure 13.44, *Pearson Physics*, p. 666),
- describe how light bends toward the normal when slowing down in a new medium, and bends away from the normal when speeding up in a new medium
- define refractive index ( $n$ ), and
- quantitatively solve problems using the formula  $n = \frac{c}{v}$ .

Introduce Snell's law,  $n_1 \sin \theta_1 = n_2 \sin \theta_2$ .

Revise the equation, considering wavelength and speed, such that

$$\frac{\sin \theta_1}{\sin \theta_2} = \frac{v_1}{v_2} = \frac{\lambda_1}{\lambda_2} = \frac{n_2}{n_1}.$$

Students should quantitatively solve problems using Snell's law; calculating wavelength, speed, refractive index, angle of incidence, and angle of refraction. Additionally, they should define and calculate the critical angle.

Students should conduct Inquiry Lab 13-6 (*Pearson Physics*, p. 671); an investigation to verify the known values of the refractive indexes of water and ethanol.

In addition to SCOs 6.0, 8.0, and 12.0, evidence may be collected to assess additional skill outcomes (e.g., 3.0, 7.0, 10.0, 11.0, 14.0, 15.0, 16.0, 17.0, and 22.0). Students may communicate their findings in a lab report. Refer to the *Integrated skills* unit for elaboration of these outcomes.

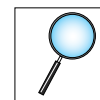

### Sample Performance Indicators

1. Determine the speed of light in water ( $n=1.33$ ).
2. Determine the angle of refraction when light rays are incident on glass ( $n=1.52$ ) and the angle of incidence is  $32^\circ$ .
3. A ray of light initially travelling in water ( $n=1.33$ ) is incident on medium X. The angle of incidence in water is  $45^\circ$  and the angle of refraction in medium X is  $29^\circ$  as shown. Draw a diagram and calculate the speed of light in medium X.
4. Determine the critical angle when light travels from air ( $n=1.00$ ) into diamond ( $n=2.42$ ).

## Wave Refraction and Snell's Law

### Sample Teaching and Assessment Strategies

#### Activation

Teachers may

- Demonstrate the “bent stick” effect to illustrate refraction.
- Introduce refraction using the PhET interactive simulation *Bending Light*.
- Demonstrate the law of reflection using a ray box and plane mirrors.

#### Connection

Teachers may

- Demonstrate the dispersion of light using a prism.

Students may

- Explore how light behaves differently as it passes through different mediums using ray boxes.

#### Consolidation

Students may

- Explain where to aim a spear and a laser to successfully catch a fish observed in the water. Draw a diagram to aid your explanation.
- Practice solving problems related to Snell's Law (*Pearson Physics*, pp. 668, 670).

#### Extension

Students may

- Research how reflection and/or refraction of light is involved in
  - making a rainbow,
  - the sparkle of a diamond, and/or
  - the creation of images in the human eye.

### Resources and Notes

#### Authorized

*Pearson Physics Level 30* (TR)

- Unit VII: Chapter 13 pp. 25-29

*Pearson Physics* (SR)

- pp. 666-671

#### Suggested

Resource Links: [www.k12pl.nl.ca/curr/10-12/science/science-courses/physics-2204/resource-links.html](http://www.k12pl.nl.ca/curr/10-12/science/science-courses/physics-2204/resource-links.html)

- Laws of reflection and refraction (websites)
- Snell's law (websites)
- PhET interactive simulations (website)

## Total Internal Reflection

### Outcomes

*Students will be expected to*

*72.0 apply the laws of reflection and the laws of refraction to predict wave behaviour [GCO 3]*

*37.0 describe and evaluate the design of technological solutions and the way they function, using scientific principles [GCO 1]*

*34.0 analyze society's influence on scientific and technological endeavours [GCO 1]*

### Focus for Learning

Students should

- describe total internal reflection,
- describe how fibre-optic cables work, and
- explain how the design of fibre-optic cables are an application of critical angle and total internal reflection.

Fibre-optic cables are designed to meet society's demand for fast, efficient digital communication. Students should investigate the advantages of fibre-optic cable use compared with metal wiring.

Students should identify additional applications of fibre optics.

### Attitude

Encourage students to consider further studies and careers in science- and technology-related fields. [GCO 4]

## Total Internal Reflection

### Sample Teaching and Assessment Strategies

#### Activation

Teachers may

- Demonstrate total internal reflection using a laser and soda bottle filled with water with a very small hole near the bottom.

#### Connection

Teachers may

- Present samples of fibre-optic cables for students to observe.
- Invite individuals who use fibre optics in their career to present to students.

Students may

- Explain the following using the concepts of critical angle and total internal reflection
  - A student resting at the bottom of a swimming pool looks directly upward and sees the lights of the pool's ceiling. As s/he begins to lower their eyes, the image changes from the ceiling lights to no image, then to the bottom of the pool.
- Investigate applications of total internal reflection in medicine and other fields.

#### Consolidation

Students may

- With the aid of a diagram, explain how a fibre-optic cable works.

### Resources and Notes

#### Authorized

*Pearson Physics Level 30 (TR)*

- Unit VII: Chapter 13  
pp. 29-30

*Pearson Physics (SR)*

- pp. 672-674

#### Suggested

Resource Links: [www.k12pl.nl.ca/curr/10-12/science/science-courses/physics-2204/resource-links.html](http://www.k12pl.nl.ca/curr/10-12/science/science-courses/physics-2204/resource-links.html)

- Fibre optics resources (websites)

DRAFT



# Appendix A: Scientific Conventions



## Scientific Conventions

Scientific information should be communicated according to accepted scientific conventions. These conventions include significant figures, formulas, units, and data (graphs, diagrams, tables). The Department of Education and Early Childhood Development follows the conventions below for public exams.

### *Significant Figures*

Any number used in a calculation should contain only figures that are considered reliable; otherwise, time and effort are wasted. Figures that are considered reliable are called significant figures. Scientific calculations generally involve numbers representing actual measurements. In a measurement, significant figures in a number consist of:

Figures (digits) definitely known + one estimated figure (digit)

They are often expressed as “all of the digits known for certain plus one that is uncertain”.

### **Significant Figure Rules**

1. All non-zero digits are significant.

2. Zero rules

- Trailing zeros (i.e., at the end to the right) of a measurement may or may not be significant:
  - If it represents a measured quantity, it is significant (e.g., 25.0 cm - the zero is significant; the decimal is clearly indicated).
  - If immediately to the left of the decimal, it is not significant (e.g., 250 cm or 2500 cm - zeros are not significant; both have 2 significant digits as there is uncertainty whether zeros are measured values).
  - If the trailing zeros in 250 cm and 2500 cm are significant, the measurements must be written in scientific notation (e.g.,  $2.50 \times 10^2$  cm or  $2.500 \times 10^3$  cm - zeros are significant).  
Note: Scientific notation is not part of the K-12 mathematics program.
- A zero, between two non-zero digits in a measurement, is significant (e.g., 9.04 cm - the zero is significant).
- Leading zeros (i.e., at the beginning to the left) are never significant (i.e., they do not represent a measured quantity), they merely locate the decimal point (e.g., 0.46 cm and 0.07 kg - the zeros are not significant).

3. Rounding with Significant Figures

In reporting a calculated measured quantity, rounding an answer to the correct number of significant figures is important if the calculated measurement is to have any meaning. The rules for rounding are listed below.

- If the figure to be dropped is less than 5, eliminate it:
  - rounding 39.949 L to three significant figures results in 39.9 L
  - rounding 40.0 g to two significant figures results in  $4.0 \times 10^1$  g
- If the figure to be dropped is greater than or equal to 5, eliminate it and raise the preceding figure by 1:
  - rounding 39.949 L to four significant figures results in 39.95 L
  - rounding 39.949 L to two significant figures results in  $4.0 \times 10^1$  L

#### 4. Multiplying and Dividing with Significant Figures

In determining the number of significant figures in a measurement that is calculated by multiplying or dividing, the measurement with the least number of significant figures should be identified. The final calculated measurement should contain the same number of significant figures as the measurement with the least number of significant figures.

$$2.1 \text{ cm} \times 3.24 \text{ cm} = 6.8 \text{ cm}^2$$

Since 2.1 cm contains two significant figures and 3.24 contains three significant figures, the calculated measurement should contain no more than two significant figures.

#### 5. Adding and Subtracting with Significant Figures

In determining the number of significant figures when adding or subtracting, the final calculation should be rounded to the same precision as the least precise measurement.

$$42.56 \text{ g} + 39.460 \text{ g} + 4.1 \text{ g} = 86.1 \text{ g}$$

Since 4.1 g has only one decimal place, the calculated measurement must be rounded to one decimal place.

#### 6. Performing a Series of Calculations with Mixed Operations

When a series of calculations is performed, it is important to remember that multiplication/division and addition/subtraction are governed by separate significant figure rules. Rounding only occurs at the last step.

When calculations involve both of these types of operations, the rules must be followed in the same order as the operations. Rounding still only occurs at the last step of the calculation.

$$\frac{(0.428 + 0.0804)}{0.009800}$$

The addition is first,  $0.428 + 0.0804 = 0.5084$ . Following the rules for addition/subtraction, the answer should have three significant figures, but rounding is the last step. Therefore, 0.5084 is used in the next step,  $0.5084 \div 0.009800 = 51.87755$ . Following the rules for multiplication/division, the answer should have four significant figures (but rounding is the last step). The sum of the numerator has three significant figures, and the denominator has four, so the final answer is rounded to three significant figures, 51.9.

In problems requiring multiple calculations (e.g., calculating final velocity and then using that value to calculate time), it is recommended that rounding only occur in the final calculation. Also, to improve accuracy and consistency, an extra digit should be carried in all intermediate calculations. Students may find it helpful to write the extra digit as a subscript (e.g.,  $39.5_4$  [3 significant figures + 1 extra]).

#### 7. Calculating with Exact Numbers

Sometimes numbers used in a calculation are exact rather than approximate. This is true when using defined quantities, including many conversion factors, and when using pure numbers. Pure or defined numbers do not affect the accuracy of a calculation. You may think of them as having an infinite number of significant figures. Calculating with exact numbers is important when dealing with conversions or calculating molar ratios in chemistry.

#### 8. Scientific Constants

Treat scientific constants as significant digits because they are rounded values (i.e., actual measured or defined values have many decimal places [e.g., the speed of light constant,  $3.00 \times 10^8$  m/s, is a rounded value based on the defined value, 299 792 458 m/s]).

## 9. Significant Figures in Logarithms

When determining the number of significant figures from a logarithm function, only the digits to the right of the decimal should be counted as significant figures.

- What is the pH of a sample of orange juice that has  $2.5 \times 10^{-4}$  mol/L hydronium ions?  
The measurement  $2.5 \times 10^{-4}$  mol/L has two significant figures. The power of ten indicates where the decimal is located (i.e. 0.00025). The pH of the sample is  $-\log(2.5 \times 10^{-4}) = 3.602\ 059$ . The digit to the left of the decimal is derived from the power of ten, therefore, it is not significant. Only two digits to the right of the decimal are significant. The answer should be recorded as 3.60.
- What is the hydronium ion concentration of orange juice with pH = 2.25?  
The pH value, 2.25, has two significant figures. The hydronium ion concentration is equal to the antilogs of -2.25. This value is 0.0056234 mol/L, which, when rounded to two significant figures, becomes 0.0056 mol/L or  $5.6 \times 10^{-3}$  mol/L.

## *Formulas and Units*

A constructed response question that requires numerical calculations often uses formulas or equations as the starting point to its solution. Proper use of formulas and units in science indicates a thorough understanding of the logic to solve a problem. For any solution that requires the mathematical manipulation of a formula, the formula should be stated at the beginning, followed by workings that clearly indicate the mathematical computations necessary to find the solution.

For most cases in science, a SI unit follows a measured value because it describes the value. Three exceptions to this are pH, equilibrium constants, and index of refraction. The final answer of a solution for a constructed response question that requires the mathematical manipulation of a formula always has a unit with the value. The workings of a solution that lead to the final answer do not have to show units.

## *Data*

Data is generally presented in the form of graphs, tables, and drawings. When these formats are used several scientific conventions should be followed.

### **Graphs**

Graphs represent relationships between numerical information in a pictorial form. Two kinds of graphs are commonly used in science courses in Newfoundland and Labrador:

- Line graph
  - used to display the relationship between continuous data
  - demonstrates a progression of values or shows how one variable changes in relation to another variable (e.g., growth of a child with age)

Note: When equations are graphed, a line or curve of best-fit must be drawn.

- Bar graph
  - used to display discrete or discontinuous data
  - consists of parallel bars whose lengths are proportional to quantities given in a set of data. The items compared are plotted along the horizontal axis and appropriate measurement is plotted along the vertical axis (e.g., populations of different types of protists in a lake).

**Graphing Rules:**

1. The graph must have a title. The title represents the relationship between the two variables.
2. The independent variable is on the horizontal x-axis.
3. The dependent variable is on the vertical y-axis.
4. Each axis is specifically labelled with units (if applicable) according to the variable it represents and values are provided with equal increments. The scale does not have to be the same on both axes, but the scales must accommodate the ranges of the two variables (i.e., the graph line or series of bars must fill  $\geq 75\%$  of the available space).  
Note: It is not necessary that both axes start at zero. See example below.
5. When data are plotted, a circle should be placed around each point to indicate a degree of error. The graph may show exact numbers or a general relationship. A best-fit line or curve must be used in line and scatter graphs.
6. A legend may be used to identify individual lines on a multi-line graph.

Moose Population in Newfoundland and Labrador (1980 - 2000)

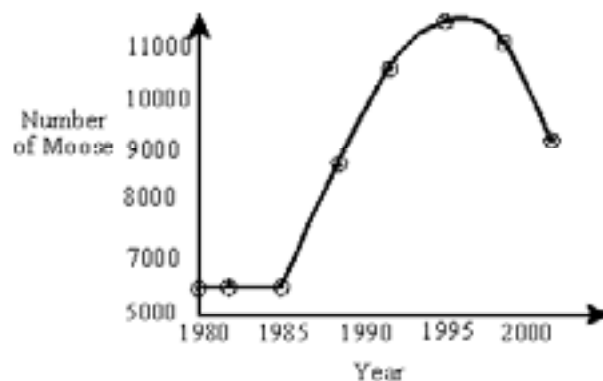
**Tables**

Tables represent numerical or textual information in an organized format. They show how different variables are related to one another by clearly labelling data in a horizontal or vertical format. As with graphs, tables must have a title that represents the relationship between the variables.

Moose Populations in Newfoundland and Labrador (1980 - 2000)

Year	Number of Moose
1980	5789
1985	6057
1990	8823
1995	11 156
2000	9315

## Drawings

Biological drawings that indicate a scale are not required. Diagrams, however, may often be used to aid explanations. These should be clear and properly labelled to indicate important aspects of the diagram.

Geological Conditions Necessary for an Artesian Well

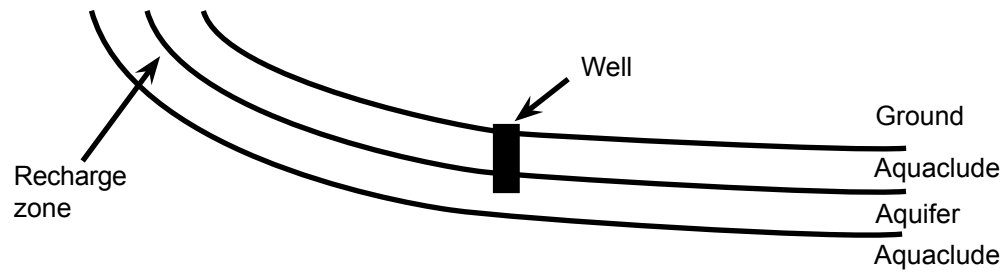



September 2018

ISBN: 978-1-55146-681-1